

## Watch Movement Specification and Drawing

Sweep Second Multi-Eye

# VH60B



Movement Size: **10 1/2"**  
 Diameter: **Φ23.70mm**  
 Height: **3.45mm**

Items	Ver.	Items	Ver.
Specification	1		
Appearance	1		
Casing	1		
Hand Fitting - 1	1		
Hand Fitting - 2	1		
Hand Setting Stem	1		
Dial	1		
Casing Ring	1		
Assembly Plan - 1	1		
Assembly Plan - 2	1		
Hands ( For TYPE M / L )	1		
Hands ( For TYPE LA )	1		

## CAL.VH60B 10½ Ligne Quartz Movement

### Three Hands ( 1/4 Center Second Hand ) with 1 eye

#### Small 24 Hour Indicator Hand

#### 1. FUNCTION

- Jewel 0 jewels
- Accuracy Less than  $\pm 15$  seconds / month (Normal temperature range)
- Battery life Approx. 2 years
- Regulation hands unbalance
  - Hour hand : Less than  $0.50 \mu\text{N}\cdot\text{m}$  ( 50 mg·mm )
  - Minute hand : Less than  $0.80 \mu\text{N}\cdot\text{m}$  ( 80 mg·mm )
  - Second hand : Less than  $0.30 \mu\text{N}\cdot\text{m}$  ( 30 mg·mm )
  - Small hand : Less than  $0.10 \mu\text{N}\cdot\text{m}$  ( 10 mg·mm )  
(24 hour indicator hand)
- The moment of inertia (For Type LA)
  - Small hand : Less than  $260 \text{ mg}\cdot\text{mm}^2$   
(24 hour disc hand)
- Additional function 24 hour indicator (Synchronized regular hour hand)

#### 2. USE AND TEST CONDITION

- Battery SR920SW (Recommended battery is SEIZAIKEN)
- Operation temperature range From  $- 5 \text{ }^\circ\text{C}$  to  $+ 50 \text{ }^\circ\text{C}$
- Antimagnetic  $\geq 1600 \text{ A / m}$  (Direct current magnetic field)
- Test of accuracy 10 seconds (Duration of measurement)

**\* All specifications are subject to change without notice.**

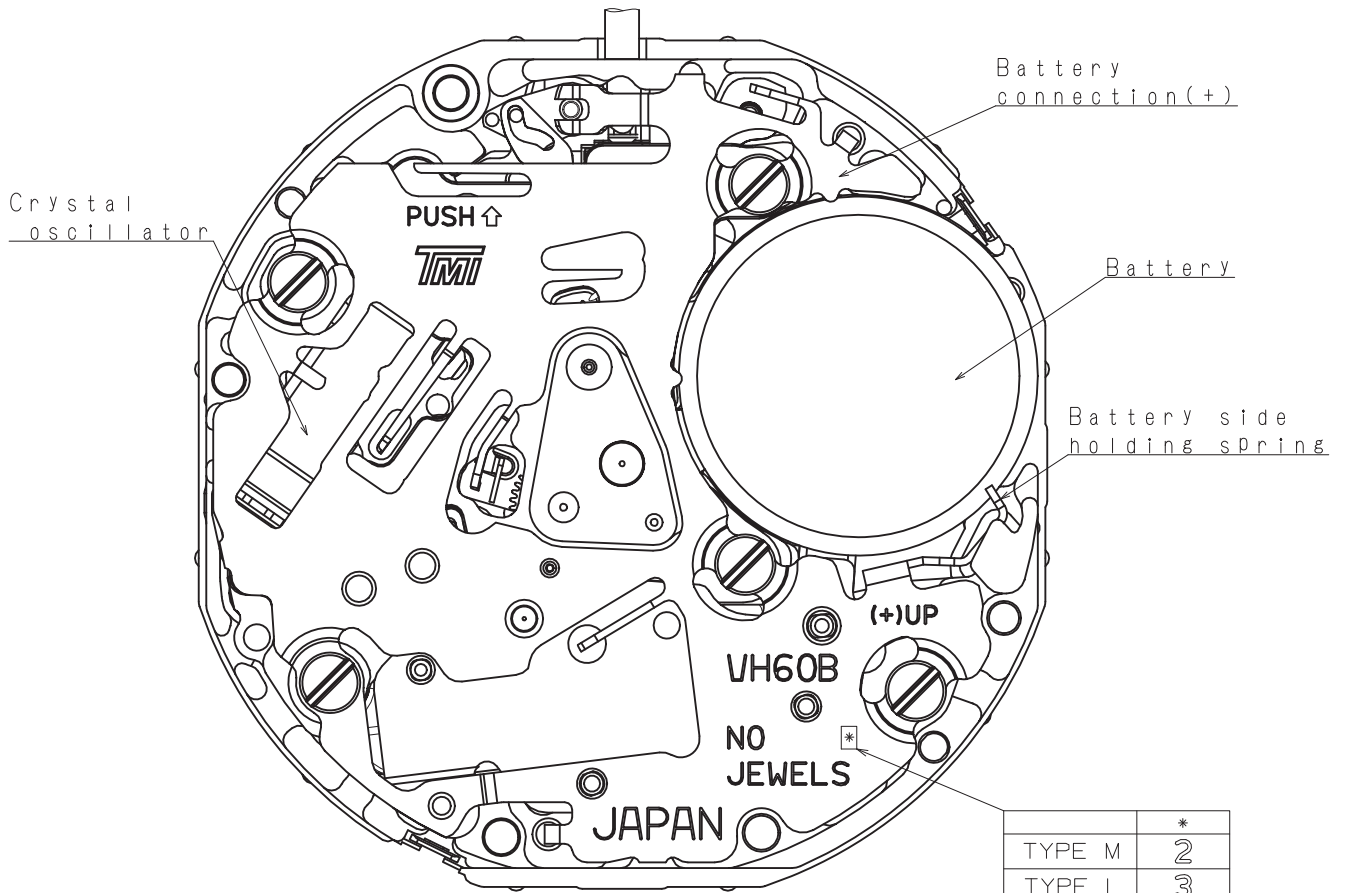

	*
TYPE M	2
TYPE L	3
TYPE LA	A

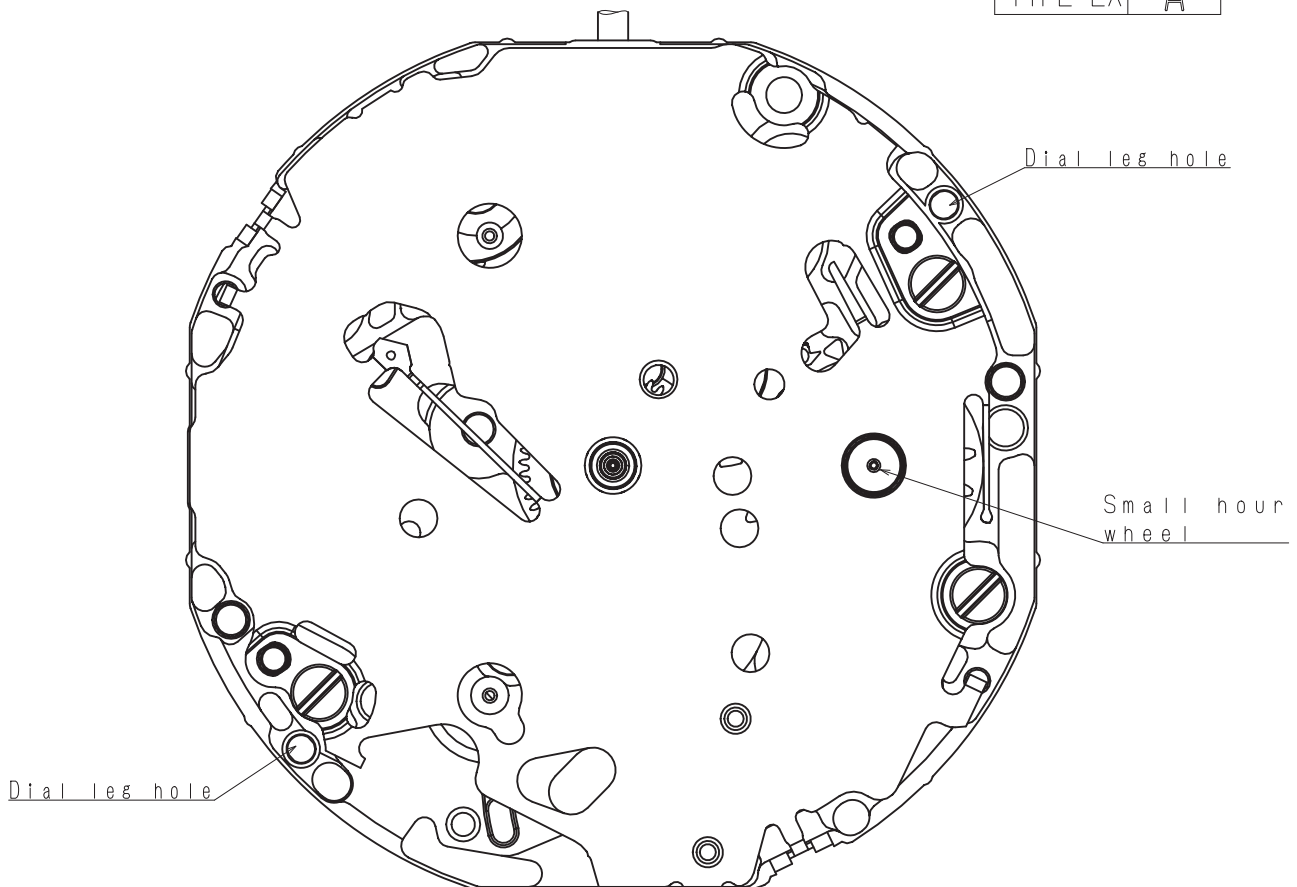

\* Pull out stroke 44.1

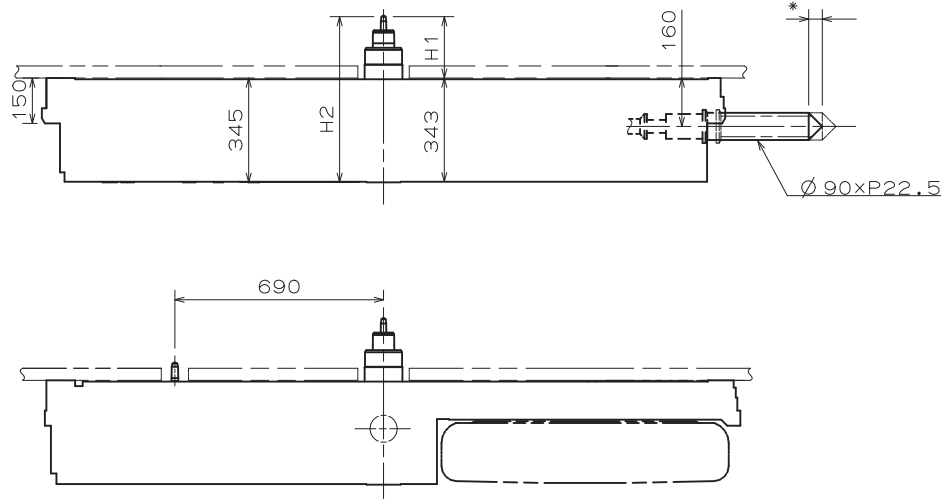

Center post 中心柱位		TYPE M 一般針高	TYPE L 高針	TYPE LA 混合針高	Hand setting stem	TYPE A	TYPE B
Maximum height from main plate surface 與機芯平面之最大高度	H1	238	293	293	L1	2436	3012
Total height incl. movement 機芯總高度	H2	583	638	638			

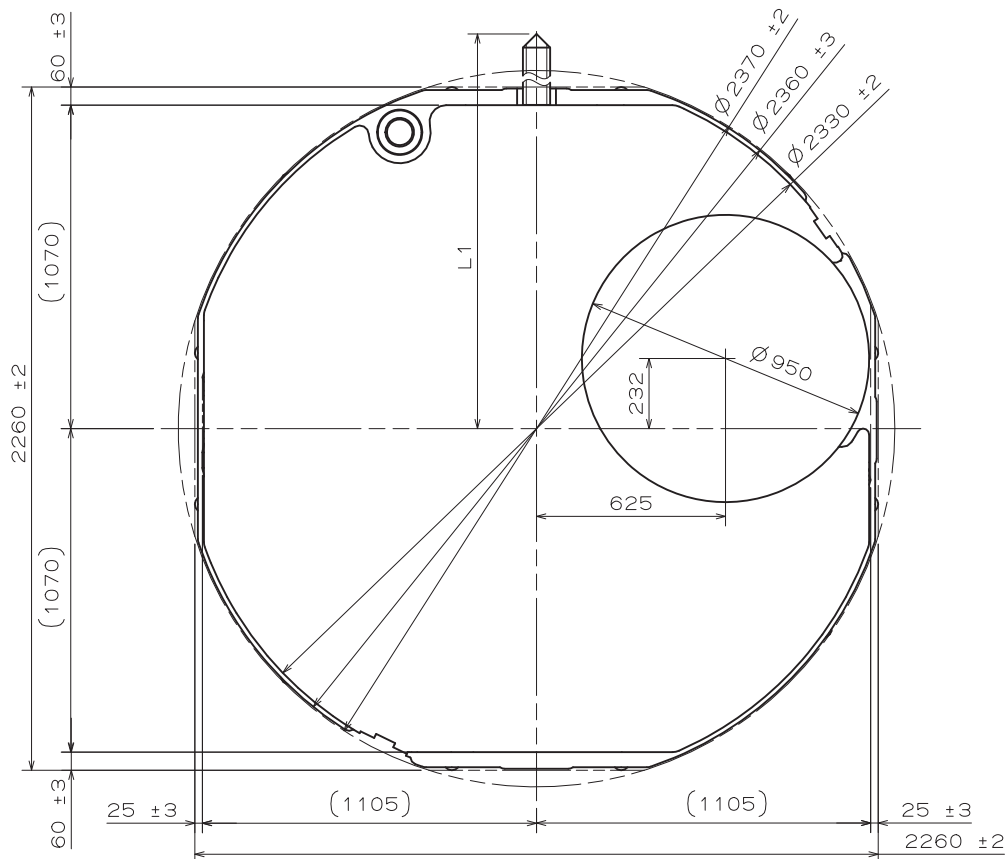

Unit : 1=1/100mm

Version : 1

## TYPE M/L

- \* Hour hand unbalance  $\leq 0.5 \mu\text{N}\cdot\text{m}$  (50mg·mm)
- \* Minute hand unbalance  $\leq 0.8 \mu\text{N}\cdot\text{m}$  (80mg·mm)
- \* Second hand unbalance  $\leq 0.3 \mu\text{N}\cdot\text{m}$  (30mg·mm)
- \* Small hour hand unbalance  $\leq 0.1 \mu\text{N}\cdot\text{m}$  (10mg·mm)

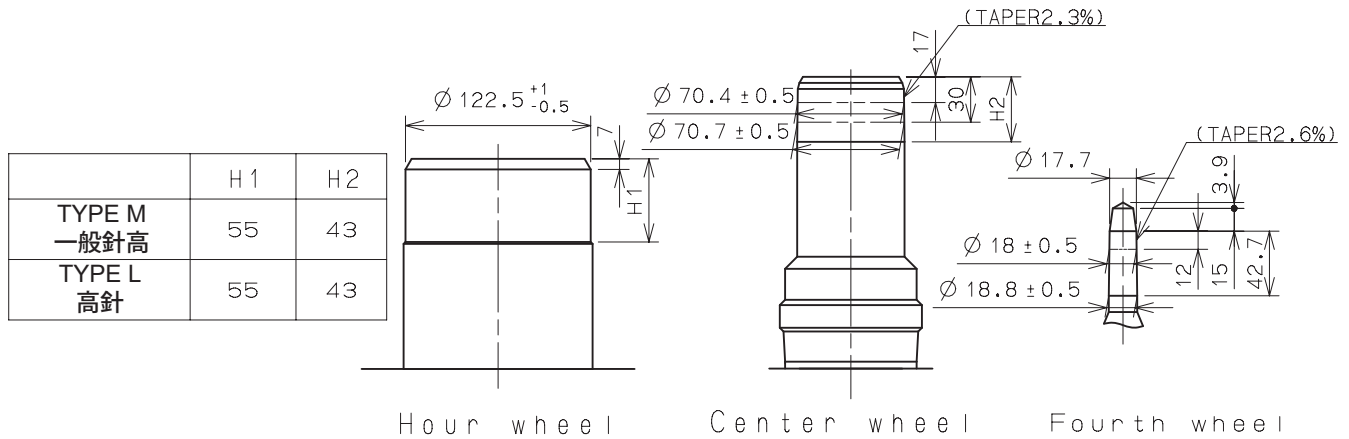

Part name		Part No.	
		TYPE M 一般針高	TYPE L 高針
Hour wheel	時針輪	0273 043	0273 045
Center wheel	分針輪	0221 089	0221 093
Fourth wheel	秒針輪	0144 004	0144 005
Small hour wheel	小時針輪	0157 018	0157 019

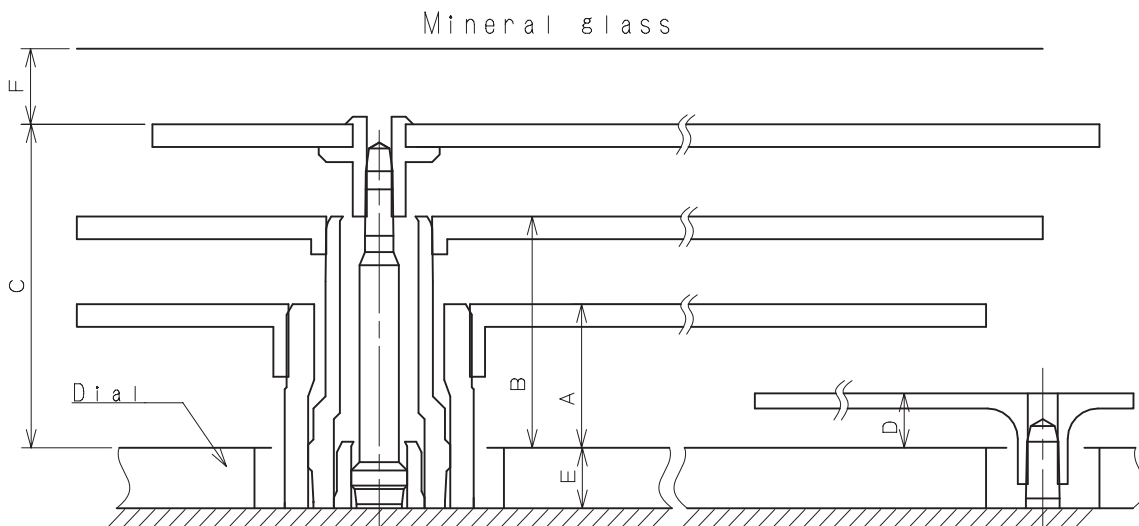
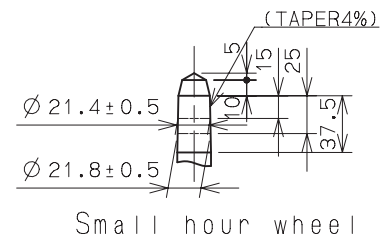

	A	B	C	D	E	F
TYPE M 一般針高	95	153	214	36	40	50
TYPE L 高針	105	163	224	46	85	50

## TYPE LA

### \*Unbalance

- Hour hand unbalance  $\leq 0.5 \mu\text{N}\cdot\text{m}$  (50mg·mm)
- Minute hand unbalance  $\leq 0.8 \mu\text{N}\cdot\text{m}$  (80mg·mm)
- Second hand unbalance  $\leq 0.3 \mu\text{N}\cdot\text{m}$  (30mg·mm)
- Small hour hand unbalance  $\leq 0.1 \mu\text{N}\cdot\text{m}$  (10mg·mm)

### \*Moment of inertia

- 24hour indicator  $\leq 0.26 \mu\text{g}\cdot\text{m}^2$  (260mg·mm<sup>2</sup>) (Disc hand available)

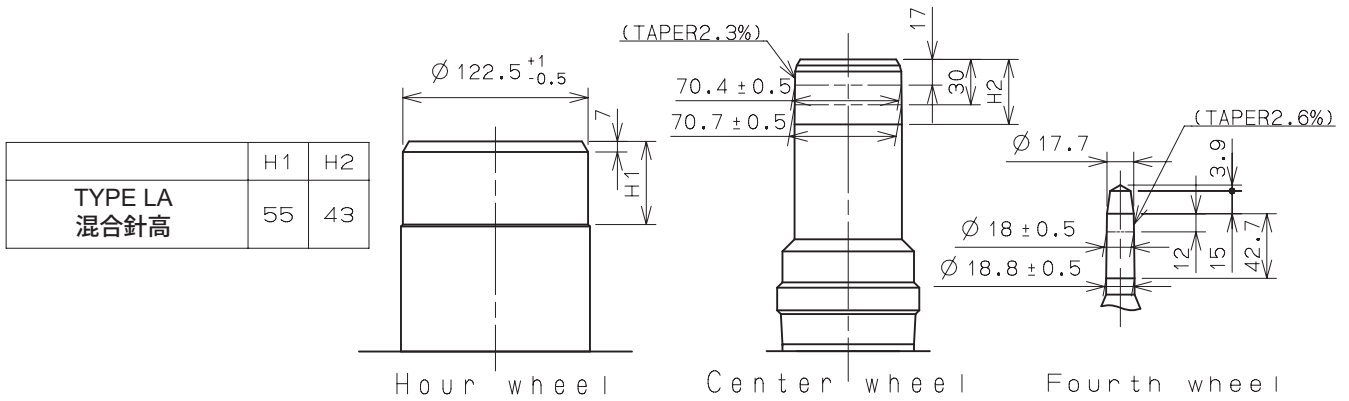

Part name	Part No.	
	TYPE LA 混合針高	
Hour wheel 時針輪	0273 045	
Center wheel 分針輪	0221 093	
Fourth wheel 秒針輪	0144 005	
Small hour wheel 小時針輪	0157 018	

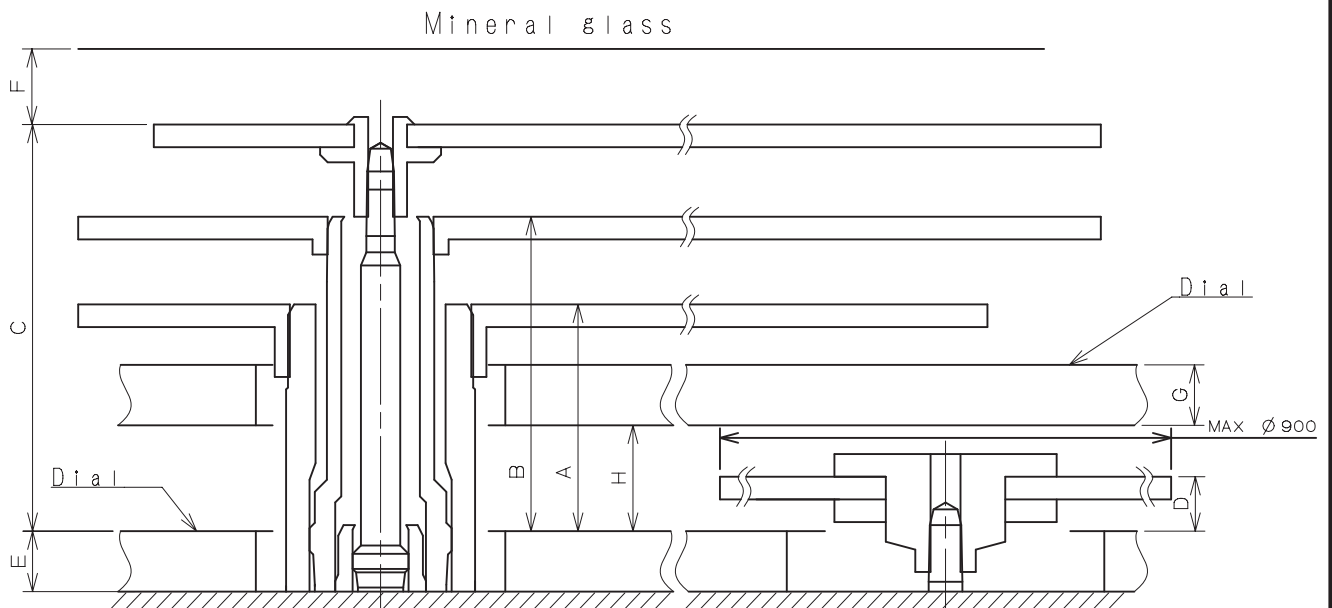
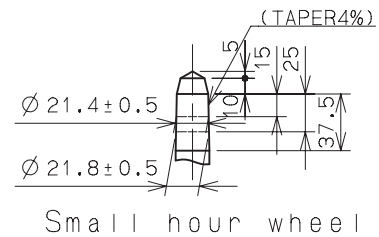

	A	B	C	D	E	F	G	H
TYPE LA 混合針高	150	208	269	36	40	50	40	70

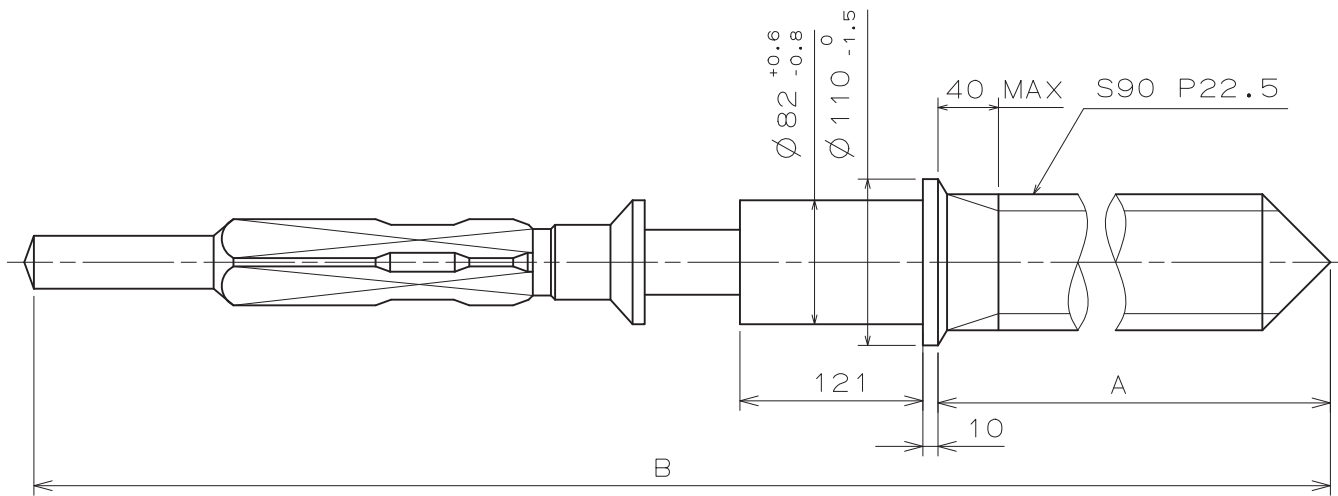

	Part No.	A	B
TYPE A	0351 177	1371	1969
TYPE B	0351 122	1947	2545

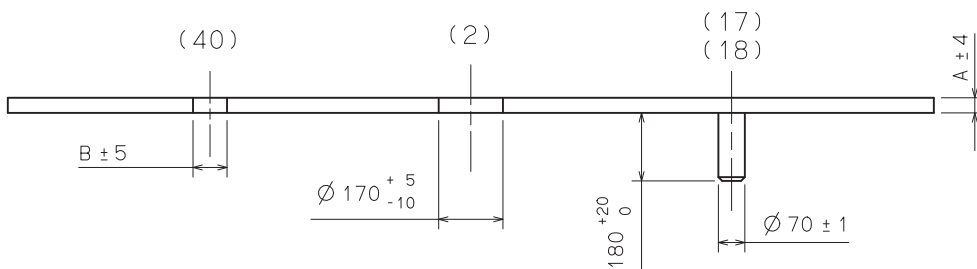
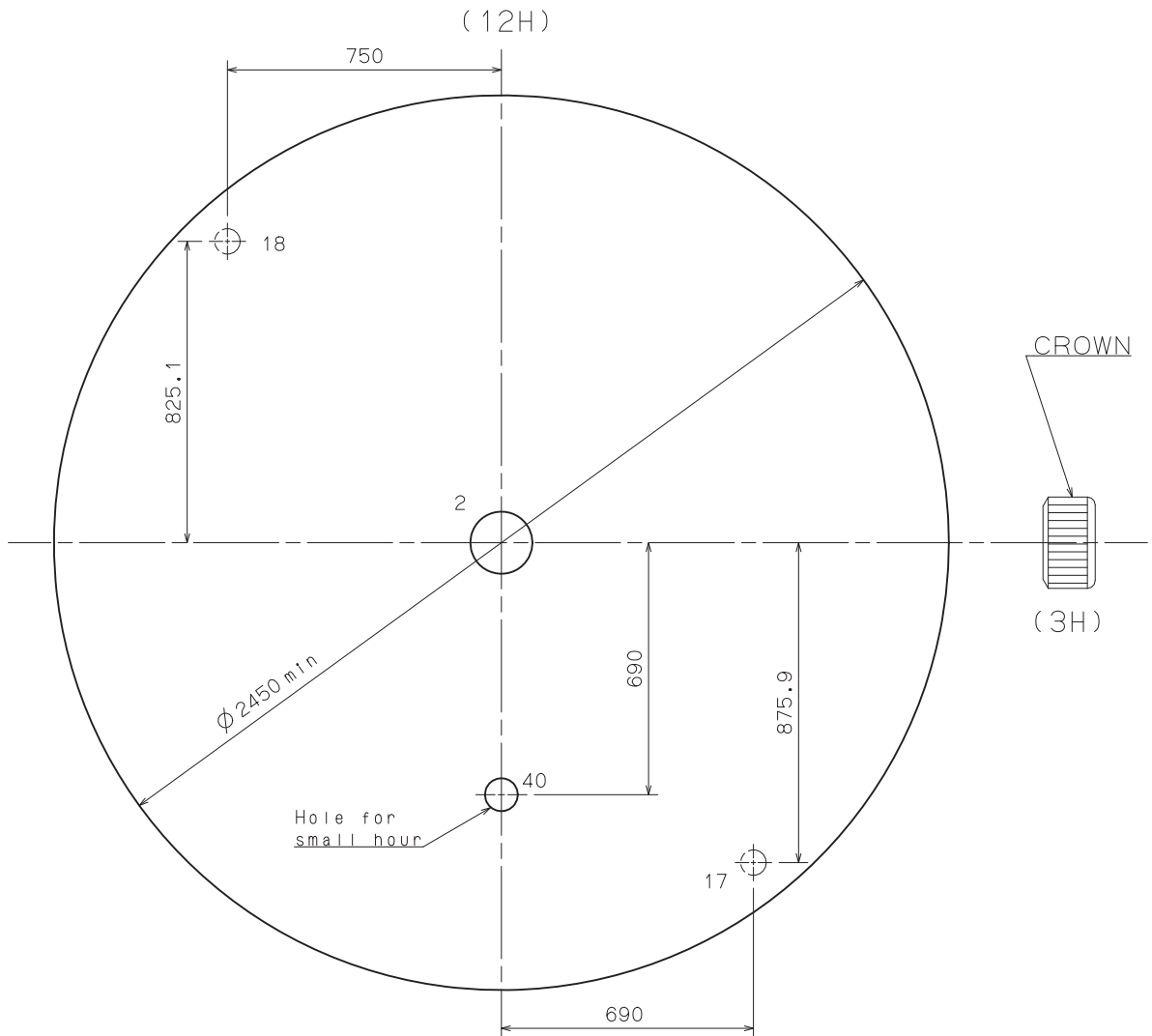

	TYPE M	TYPE L	TYPE LA
A	40	85	40(*)
B	$\Phi 90$	$\Phi 90$	$\Phi 210(*)$

\* Lower layer dial







## TYPE LA

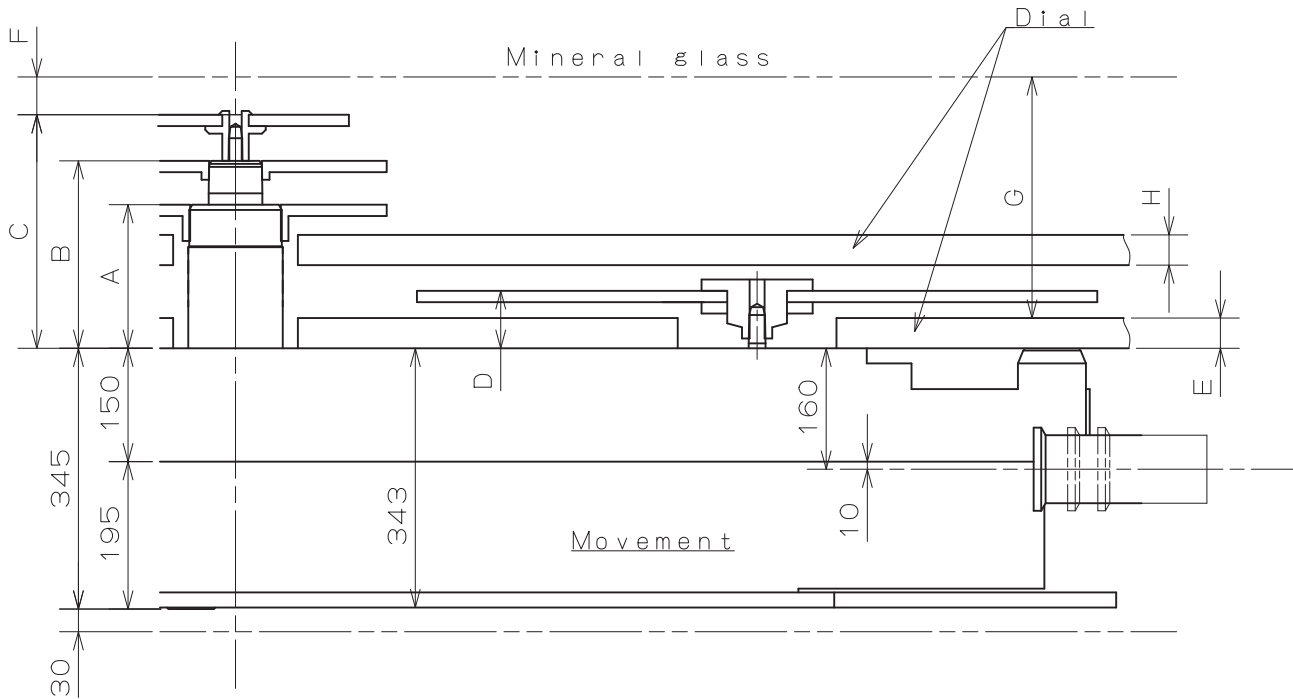

	A	B	C	D	E	F	G	H
TYPE LA	190	248	309	76	40	50	319	40

\*Recommended dimension (Clearance of dial and case body) : 15

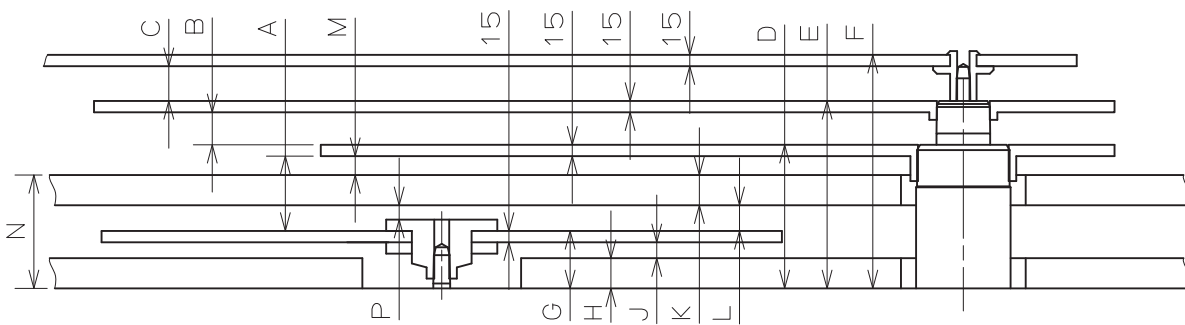

	A	B	C	D	E	F	G	H	J	K	L	M	N	P
TYPE LA	99	43	46	190	248	309	76	40	21	40	34	25	150	19

Unit : 1=1/100mm

Version : 1

SECOND

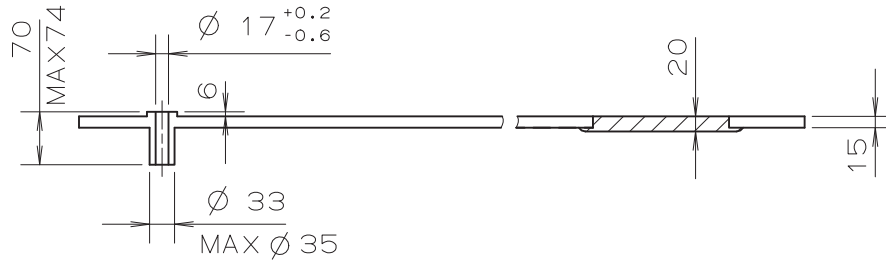

MINUTE

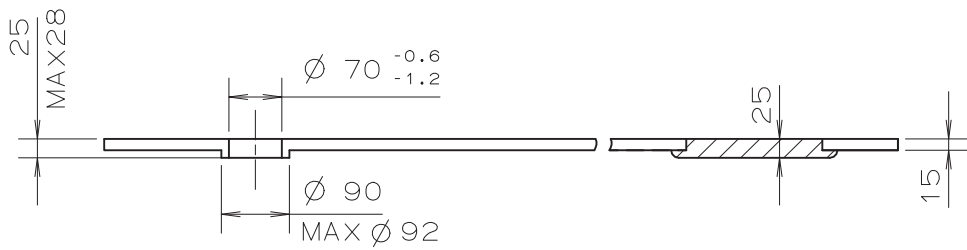

HOUR

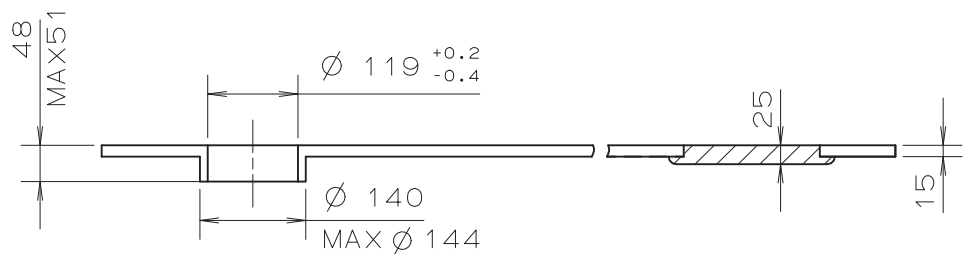

SMALL HOUR

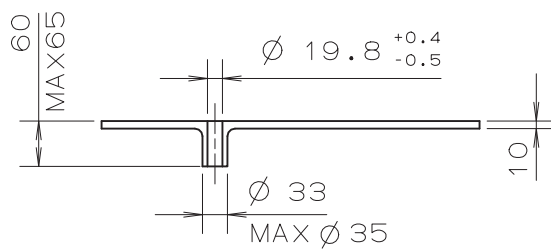

## SECOND

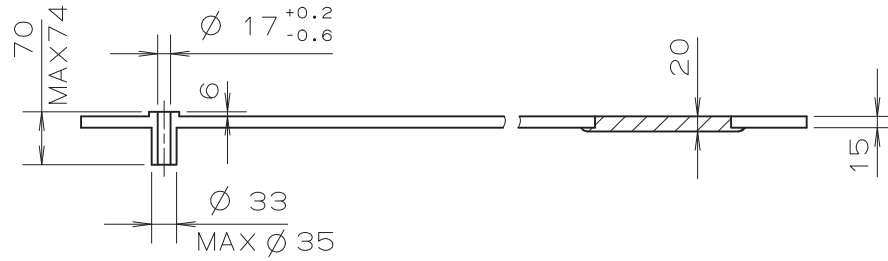

## MINUTE

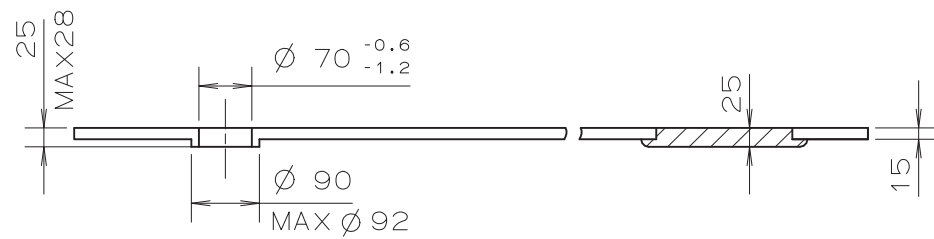

## HOUR

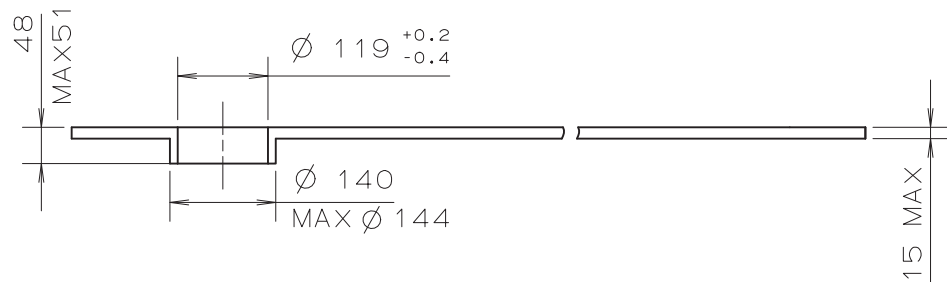

## SMALL HOUR

