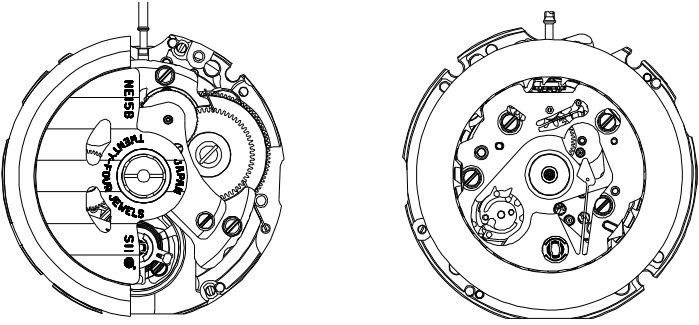

**TECHNICAL GUIDE
&
PARTS CATALOGUE**

Cal.NE15B

AUTOMATIC MECHANICAL

SII Products

	Cal. No.	NE15B	
Movement			
Movement size	Outside diameter	Φ 27.40mm	
	Casing diameter	Φ 27.00mm	
	Total height	5.32mm	
Time indication	3 Hands (Hour , Minute , Second) Date Calendar		
Basic function	Manual winding Automatic winding with ball bearing Time setting with stop second device Date display with quick date correction		
Frequency	21,600 vibrations per hour		
Accuracy	Static accuracy	-15~+25 seconds per day * Measurement should be done within 10~60 minutes after fully wound up. * All measurements are made without the calendar in function.	
	Measurement position	Direction of 3 positions. (1) Dial up (2) 9 o'clock up (3) 6 o'clock up	
	Lift angle	53 deg.	
	Measurement time	20 seconds * Equipment to be used : Witschi WATCH EXPERT	
	Posture difference	Difference is under 45 seconds within max value and minimum value. * Measurement should be done within 10~60 minutes after fully wound up. * Direction of 4 positions. (1) 12 o'clock up (2) 9 o'clock up (3) 6 o'clock up (4) 3 o'clock up	
	Isochronisms (24h-0h)	-10~+20 seconds per day. * Direction of position. : Dial up * Difference of static accuracy of 24h and 0h	
Duration time	More than 50 hours ... Mainspring after fully wound up. * Posture to confirmation : Dial up		
Winding the mainspring	<< Movements >> • Fully wound up by turning the crown minimum 55 times. • Fully wound up by turning the ratchet wheel screw 8 times. << Complete Watch >> A winding machine is needed to wind up the mainspring. Full wind up conditions • Rotary speed : 30 rpm • Operating time : 60 minute		
Jewels	24 jewels		
Crown position		Left rotation	Right rotation
	Normal position	Free	Manual winding
	First click	Date setting	Free
	Second click	Time setting with stop-second device	

Disassembling procedures Figs.

① → ⑤②

Reassembling procedures Figs.

⑤② → ①

Type of oil

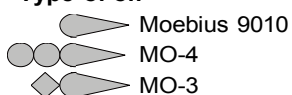

Oil quantity mark

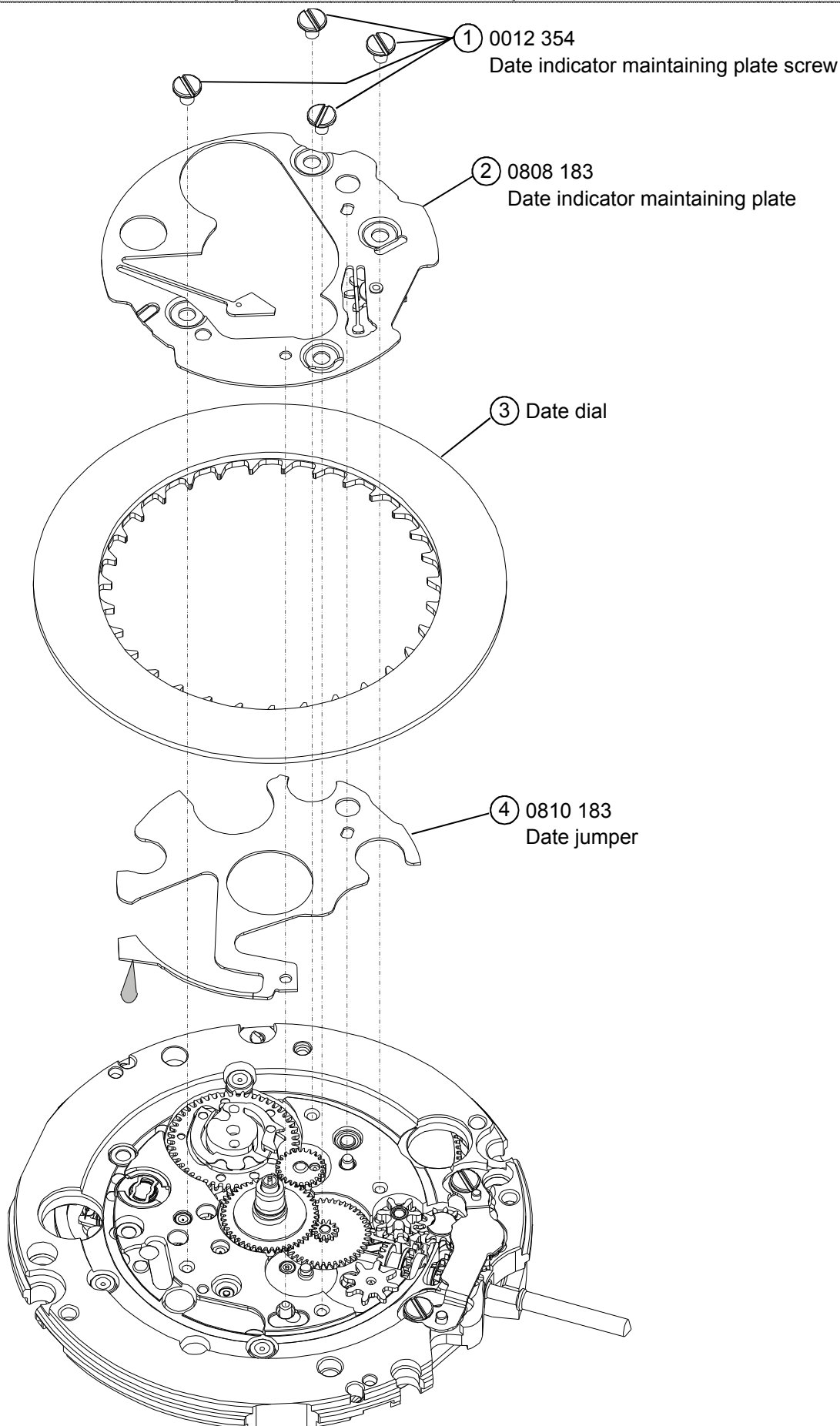
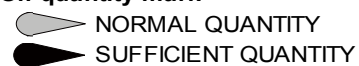

Type of oil

Moebius 9010

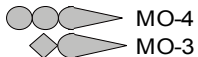

MO-4

MO-3

Oil quantity mark

NORMAL QUANTITY

SUFFICIENT QUANTITY

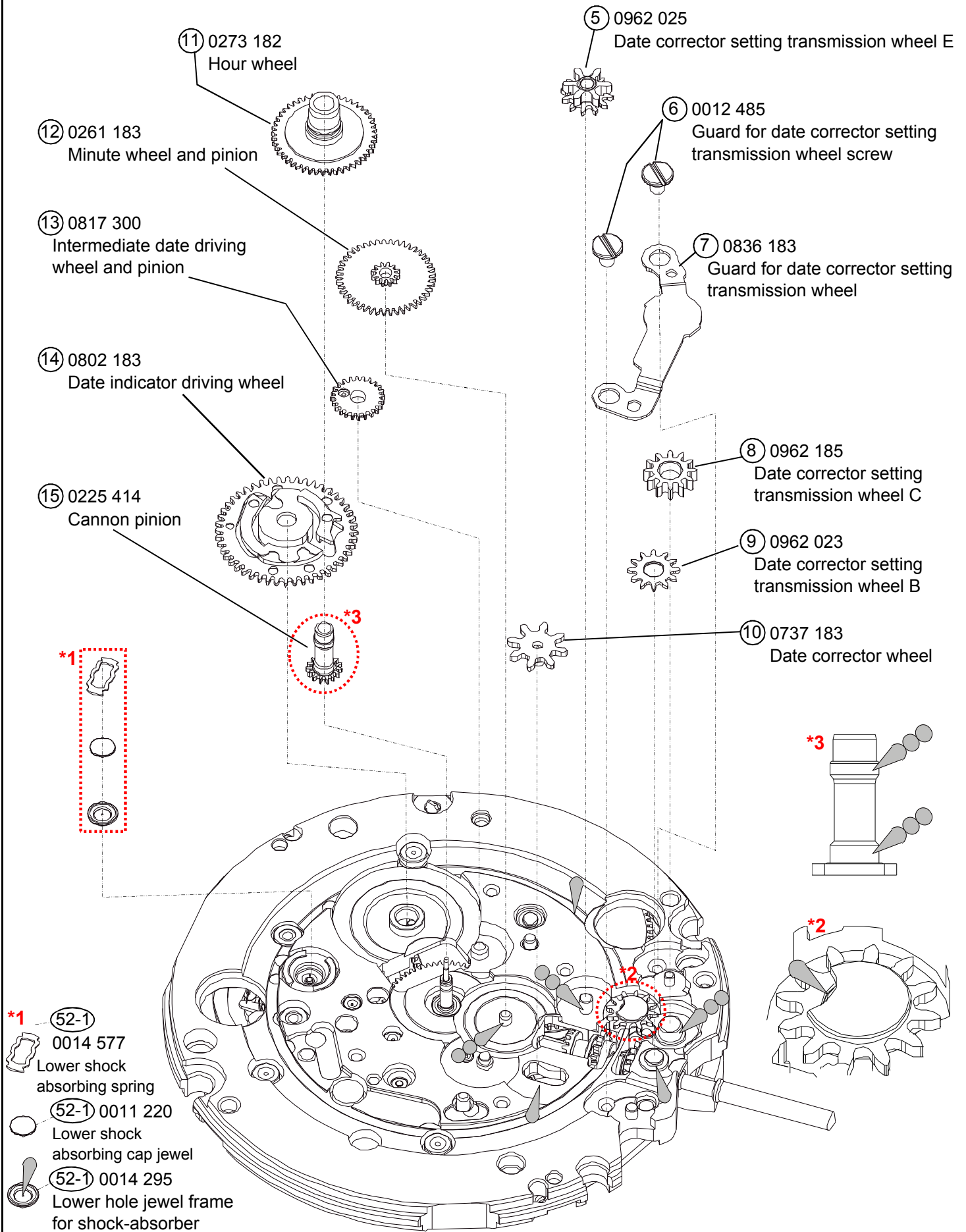

Type of oil

Moebius 9010

MO-4
MO-3

Oil quantity mark

NORMAL QUANTITY
SUFFICIENT QUANTITY

⑩ 0509 401
Oscillating weight with ball bearing

⑫ 0012 420
Balance bridge screw

⑬ 0171 354
Balance cock

⑬-1 0310 047
Balance complete with stud

*1 ⑬-2 0014 577
Upper shock absorbing spring

⑬-3 0011 220
Upper shock absorbing cap jewel

⑬-4 0014 295
Upper hole jewel frame for shock-absorber

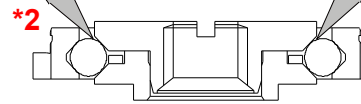

⑰ 0012 354
Automatic train bridge screw

⑱ 0191 183
Automatic train bridge

whole tooth
⑲ 0514 183
Second reduction wheel and pinion

⑳ 0012 919
Ratchet wheel screw

㉑ 0285 051
Ratchet wheel

㉒ 0012 354
Pallet bridge screw

㉓ 0161 300
Pallet bridge

㉔ 0301 009
Pallet fork

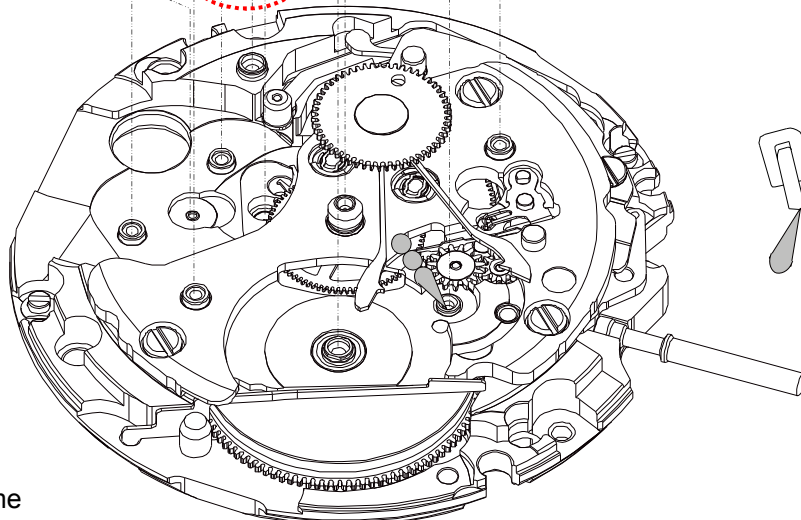
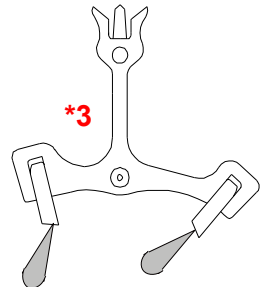
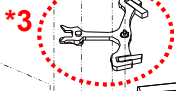

Type of oil

Moebius 9010

MO-4
MO-3

Oil quantity mark

NORMAL QUANTITY
SUFFICIENT QUANTITY

32 0511 010

First reduction wheel

Refer to page 8 for oiling spot

31 0831 183

Pawl lever

30 0836 002

Reduction wheel holder

35 0241 010

Fourth wheel and pinion

27 0012 420

Barrel and train wheel bridge screw

28-1 0015 703

Cap jewelled spring

28-2 0011 221

Cap jewel

29 0363 184

Ratchet sliding wheel spring

Refer to page 10 for the assembling method.

28 0114 183

Barrel and train wheel bridge with hole jewel frame

Refer to page 8 for oiling spot

34 0436 164

Lower plate for barrel and train wheel bridge

33 0012 354

Lower plate for barrel and train wheel bridge screw

36 0231 070

Third wheel and pinion

37 0381 004

Click

38 0201 164

Barrel complete with mainspring

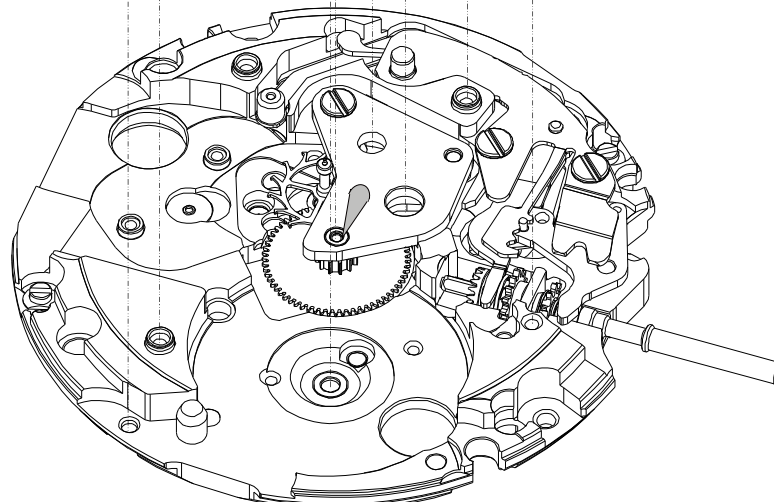
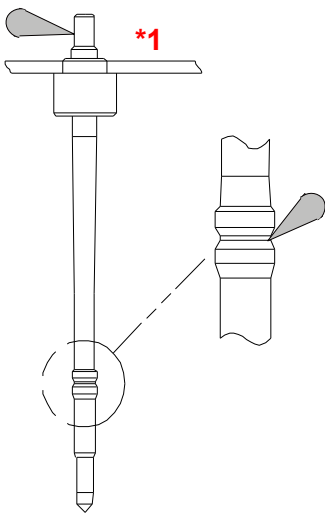

Type of oil

Moebius 9010

MO-4
MO-3

Oil quantity mark

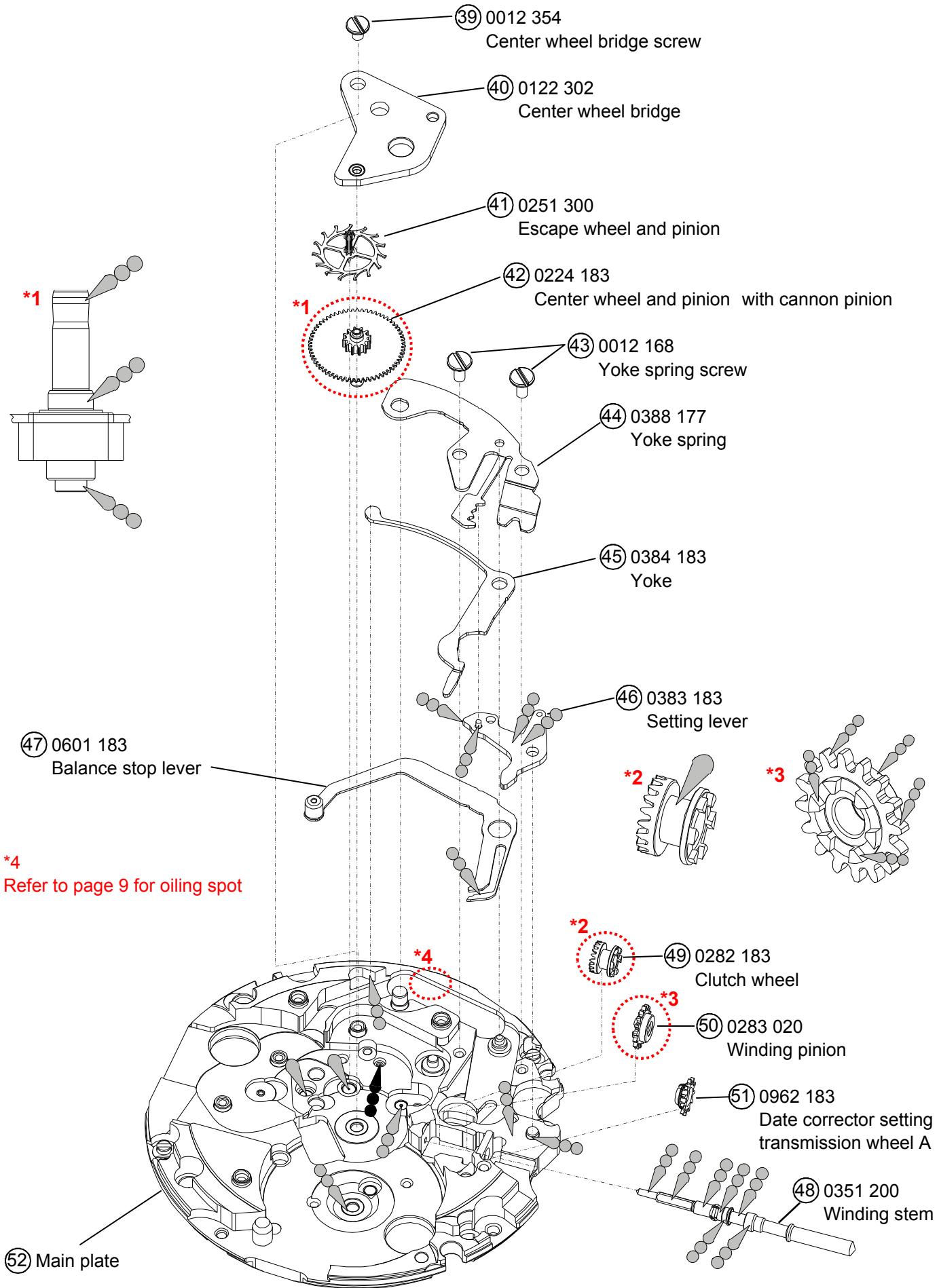

NORMAL QUANTITY
SUFFICIENT QUANTITY





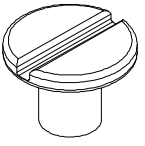
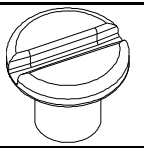
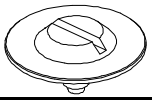
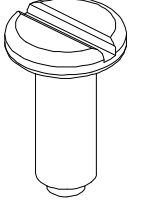

③ **Date dial**

Parts code	Position of crown	Position of day frame	Color of letters	Color of background
0878 208	3H	3H	Black	White

■ **List of screw**

No	Parts code	Parts name	Parts form	No	Parts code	Parts name	Parts form
①	0012 354	Date indicator maintaining plate screw (x4)		⑥	0012 485	Guard for date corrector setting transmission wheel screw (x2)	
⑱		Automatic train bridge screw (x2)		⑳	0012 919	Ratchet wheel screw	
⑳		Pallet bridge screw (x2)		㉒	0012 420	Balance bridge screw	
㉓		Lower plate for barrel and train wheel bridge screw		㉔			
㉕		Center wheel bridge screw		㉖			
㉗	0012 168	Yoke spring screw (x2)					

Type of oil	Oil quantity mark
 Moebius 9010	 NORMAL QUANTITY
 MO-4	 SUFFICIENT QUANTITY
 MO-3	

1.Oiling spot

⑳ Barrel and train wheel bridge with hole jewel frame

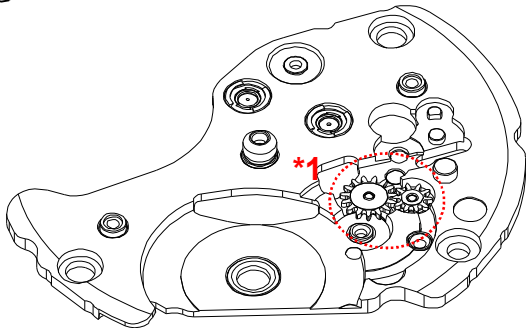

*1

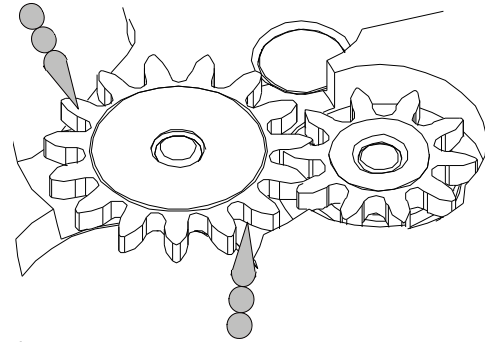

Barrel and train wheel bridge with hole jewel frame (back side)

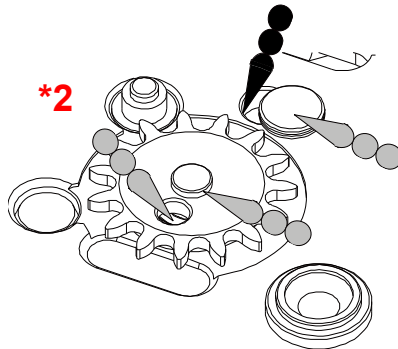
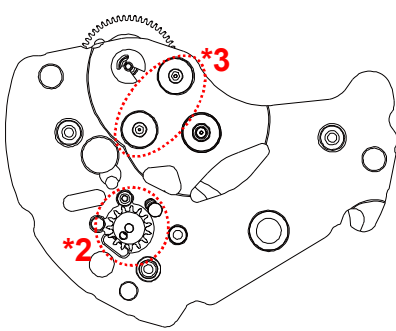

*2

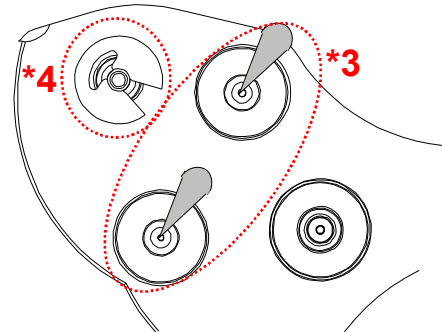

*4

*3

Note

***2 After oiling, set lower plate for barrel and train wheel bridge & screw.**

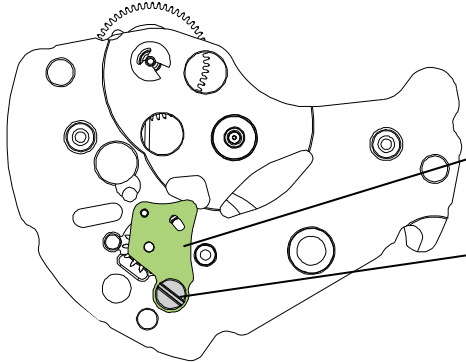

⑳ Lower plate for barrel and train wheel bridge

㉓ Lower plate for barrel and train wheel bridge screw

***4 After oiling, set first reduction wheel & pawl lever & reduction wheel holder.**

㉒ First reduction wheel

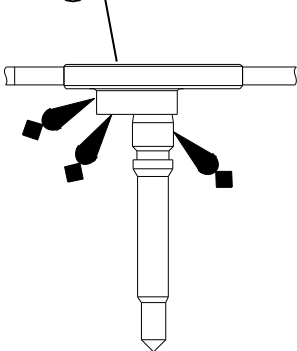

㉒ First reduction wheel

㉑ Pawl lever

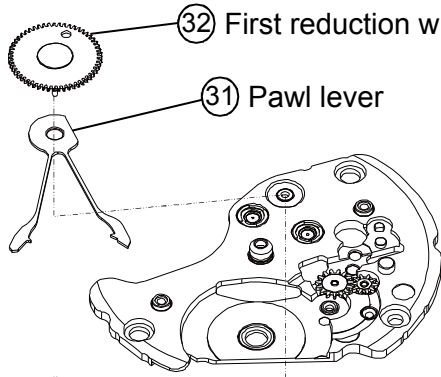

㉒ Reduction wheel holder

④7 Balance stop lever

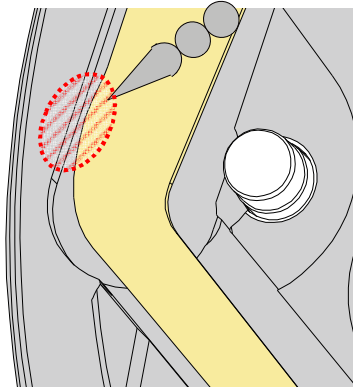
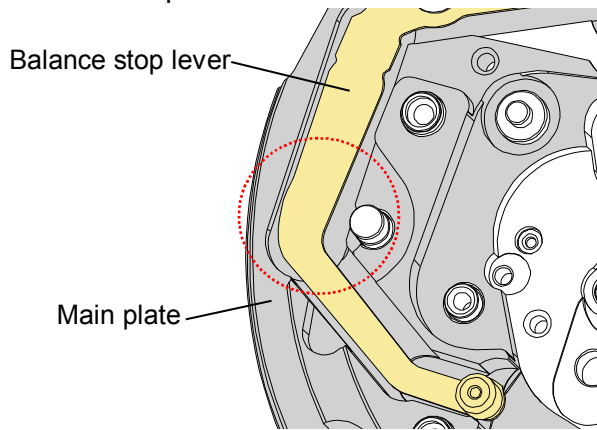

Contact part of main plate and balance stop lever

2. Setting position of oscillating weight

• Before assembling oscillating weight.

Match the center of the oscillating weight and winding stem. Set the hole of first reduction wheel gear on the imaginary line toward the balance bridge guide pin.

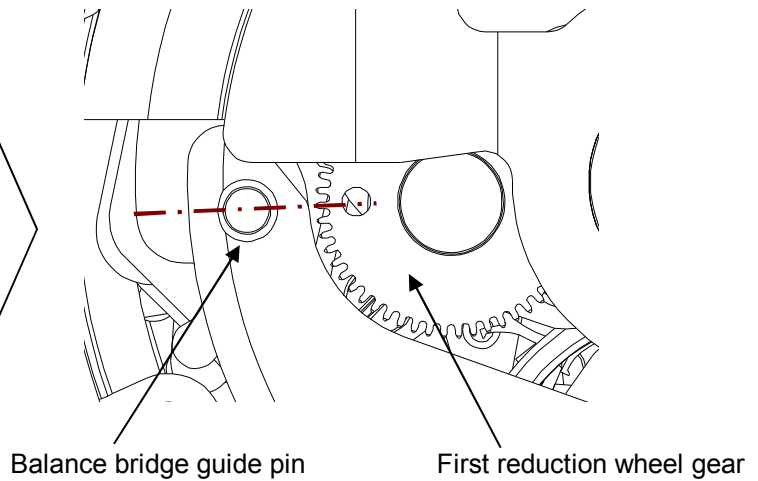
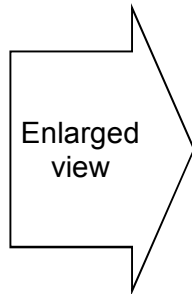
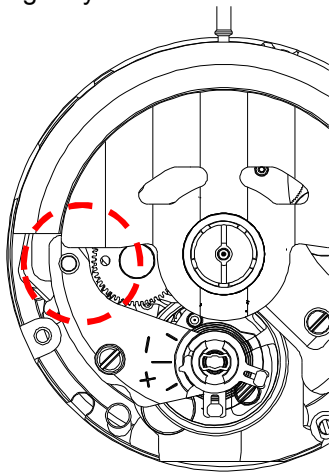

3. To remove the winding stem

- 1) Set the winding stem to normal position.
- 2) Pull out the winding stem, while pushing "A"

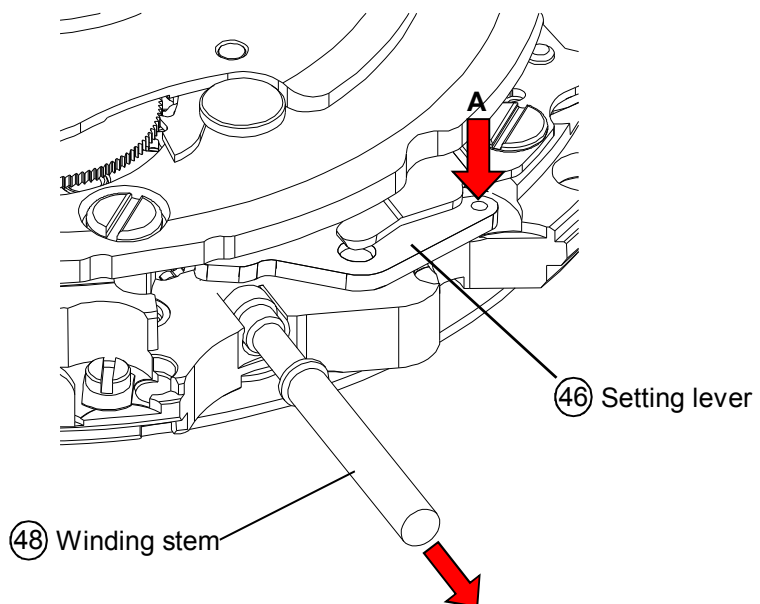

4. Disassembling / assembling of the First reduction wheel

<< Disassembling >>

<< Assembling >>

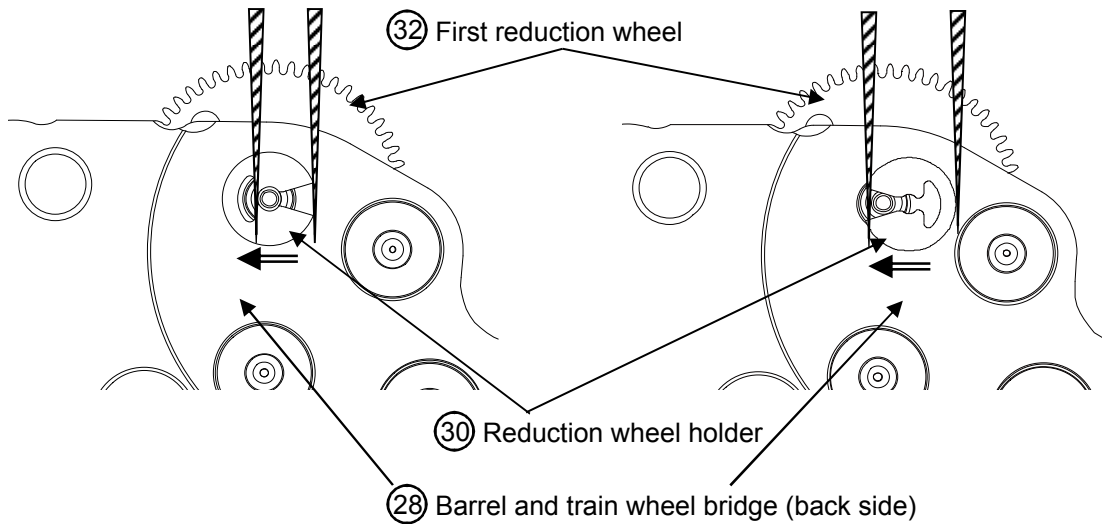

5. Disassembling / assembling of the Ratchet sliding wheel spring.

<< Disassembling >>

<< Assembling >>

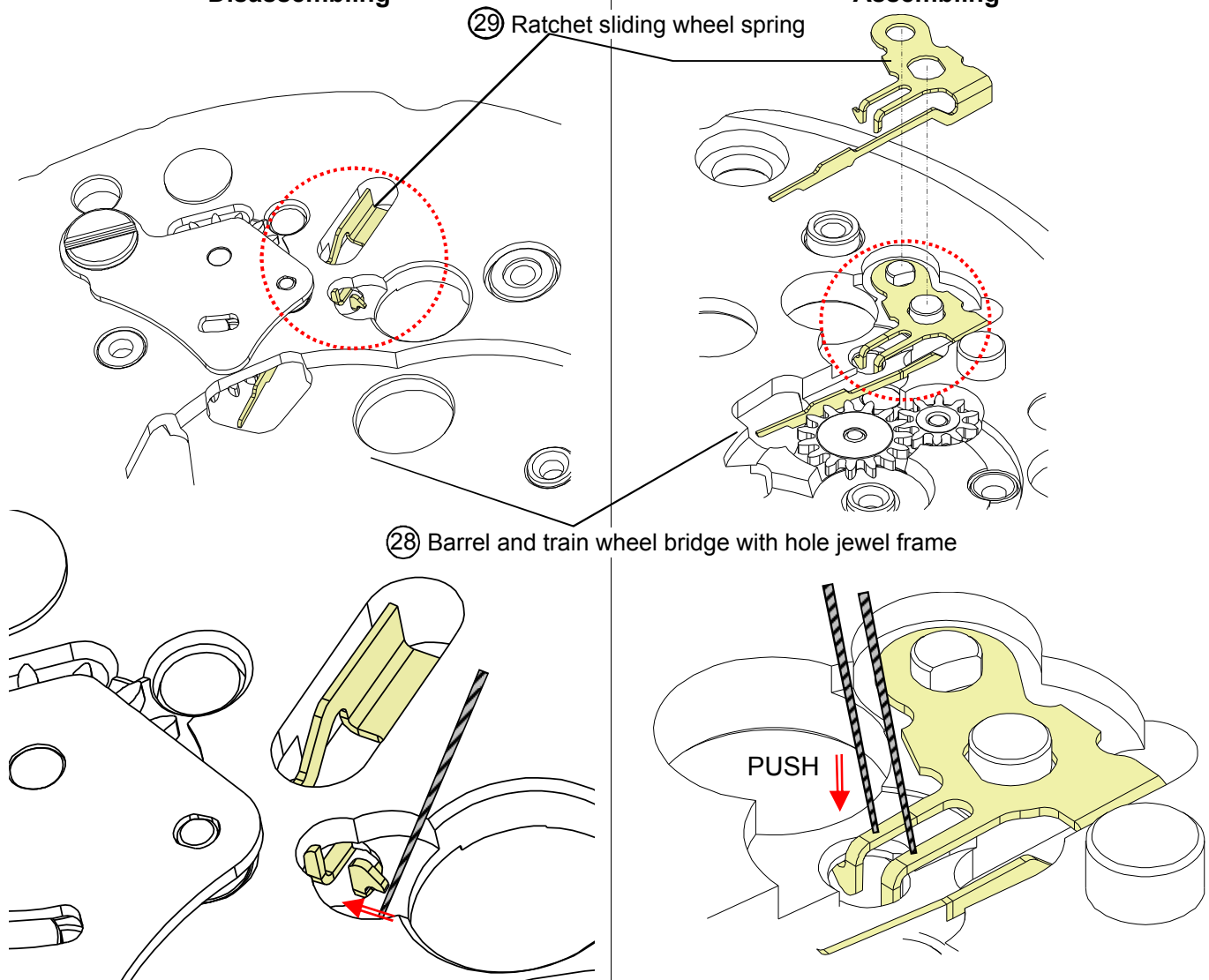

Remove the hook of the ratchet sliding wheel spring from barrel and train wheel bridge with hole jewel frame.

The hooks of ratchet sliding wheel spring are hung up on barrel and train wheel bridge with hole jewel frame.

6.Accuracy adjustment

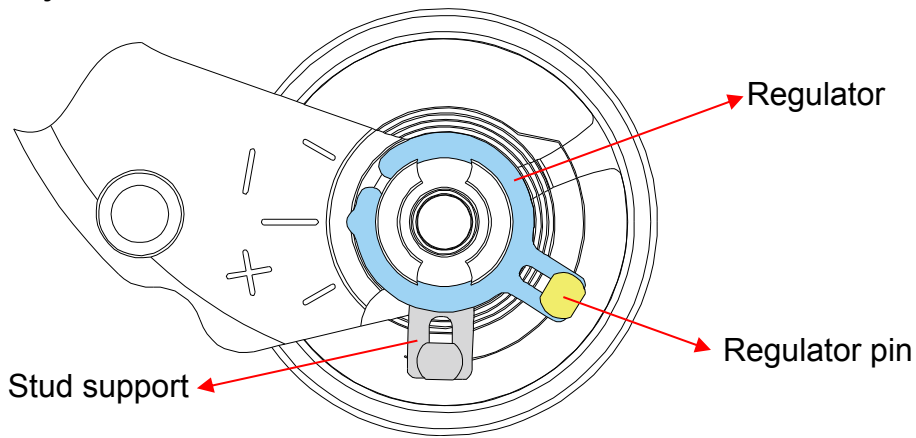

Note:

•Regulator ... Time adjustment

•Stud support ... Beat error adjustment

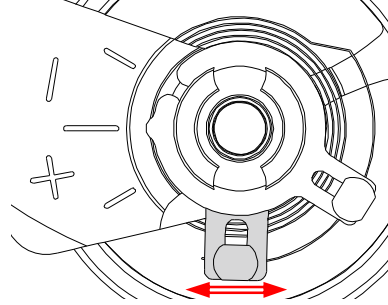
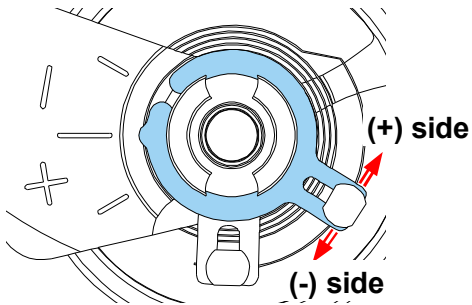

•Regulator pin ... Gap adjustment of balance spring and regulator pin

Anticlockwise rotation

No clockwise rotation

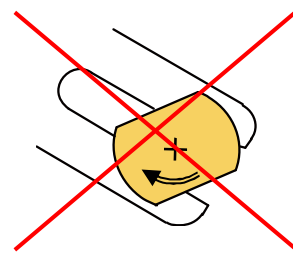
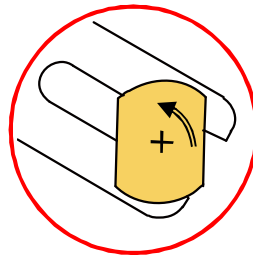
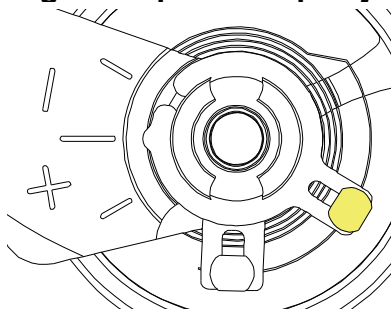

7.To wind up the mainspring

<<Movement>>

The mainspring would be fully wound up by turning the ratchet wheel screw 8 times clockwise. (Manual winding or Screwdriver)

Manual winding ... Rotate crown clockwise at normal position by min 55 times. (Equal to ratchet wheel screw 8 times)

Screwdriver winding ... Turn the ratchet wheel screw 8 times clockwise.

[Manual winding]

[Screwdriver winding]

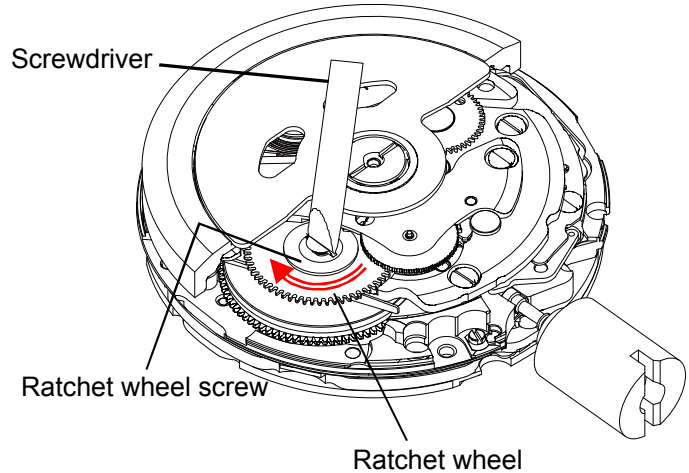
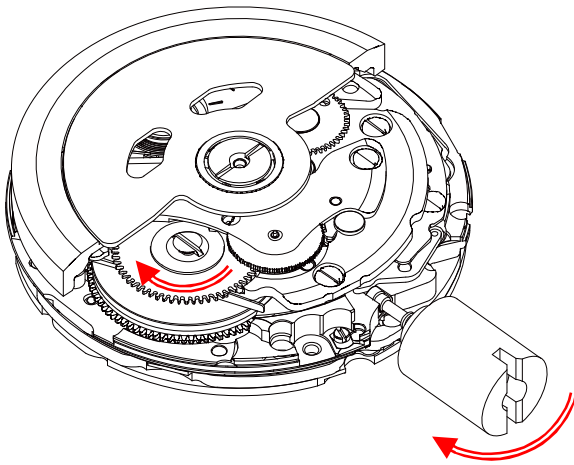

8.How to attach hands

Place the movement directly on a flat metal plate or something similar to attach the hands.

We recommend the use of movement holder to attach hands.

For hands attachment, please use a special equipment.

When the movement receives a strong shock, it may be damaged.

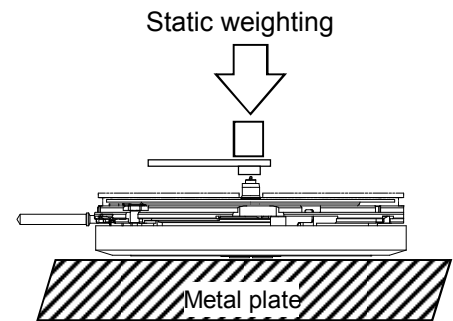

9.Accuracy measurement condition

Static Accuracy : -15~+25 seconds per day

Measurement Conditions

- 1) Measurement should be done within 10~60 minutes after fully wound up.
- 2) Lift angle : 53 deg
- 3) Measurement position : (1) Dial up (2) 9 o'clock up (3) 6 o'clock up
- 4) Minimum measurement Time : 20 seconds
- 5) Stabilizing Time :

Leave the watch for at least 20 seconds to stabilize after you change its measurement position.

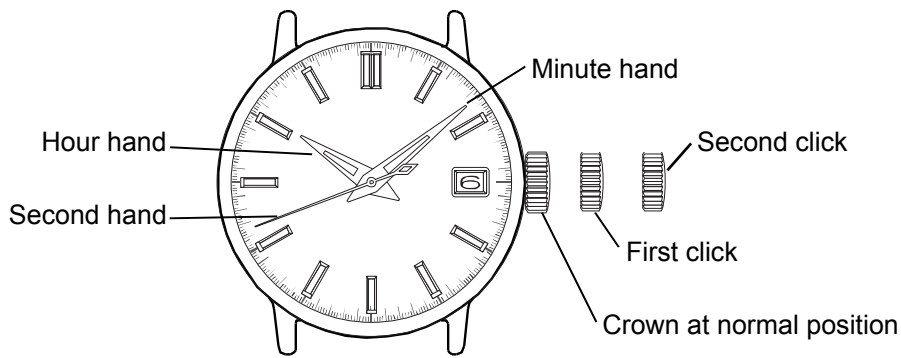
**1. Time setting**

- 1) Pull out the crown to the second click position.
- 2) Turn the crown to set hour and minute hands.
(Check that AM/PM is set correctly.)
- 3) Push the crown back into the normal position.

2. Date setting

- 1) Pull out the crown to the first click position.
- 2) Turn the crown to left for date setting.
* Do not set the calendar between 10:00 P.M. and 1:00 A.M. If the setting of the calendar is made during this period, the date will not change to the next date. Please set the calendar after changing the time other than the above period.
- 3) Push the crown back into the normal position.

3. To wind up the mainspring

- a) Manual winding ... Rotate the crown clockwise at normal position.
Wind turning the ratchet wheel screw 8 times. It will start to move naturally after shaking slightly.
- b) To wind up with winding machine.
Full wind up conditions
 - Rotary speed : 30 rpm
 - Operating time : 60 minutes