



Cal. YM88A

ϕ 27.0 mm
H 4.42 mm

Items	Rev.	Page
Specifications	00	1
Appearance	00	2
Casing	01	3
Hand fitting	00	4
Hand setting stem	01	5
Magnetic shield plate	00	6
Dial	00	7
Casing ring	00	8
Attention for assembly	00	9
Attention of casing part structure	00	10
Attention of dial design	00	11
Operation-01	00	12-01
Operation-02	00	12-02

Date: 26/Dec./'11

S.EPSON Products

CAL. YM88A

Analog Quartz 12" Center second Chronograph and Timer Movement

1. MOVEMENT DIMENSIONS

Outside diameter	ϕ 27.60mm (12H-6H) × 24.00mm (3H-9H)
Casing diameter	ϕ 27.00mm (12H-6H)
Total height	4.42mm (including battery)

2. TIME STANDARD

Type of quartz oscillator	Tuning fork
Frequency of quartz oscillator	32,768 Hz
Accuracy	±20 seconds per month (on wrist)
Operating temperature range	-5°C to +50°C
Regulation device	Nil (Pre-adjusted)

3. INDICATOR / FUNCTIONS

3 Hands	Hour hand / Minute hand / 1/5second chronograph hand (Center)
Small hands	Small second hand (9H) / Minute chronograph hand (6H) 24 Hour hand (3H)
Calendar	Instant setting device for date calendar
Reset switch	
Power depletion warning function (BLD)	
(Small second hand moves at 2-second intervals)	
Setting mechanism	Crown at normal position : Free Crown pulled out 1st click : Instant date change / Timer setting Crown pulled out 2nd click : Time setting / Reset : Chronograph hand reset
Stopwatch	2H button: start / stop 4H button: sprit / reset
Timer	2H button: start / stop 4H button: Extend timer measurement time / reset

4. FEATURES

Jewels	0 Jewel
Anti-magnetism	Over 1600A/m (Direct current magnetic field)
Maximum unbalance of hands	Small second hand : 0.03 μ N·m 24 Hour hand : 0.03 μ N·m Minute chronograph hand : 0.03 μ N·m 1/5 second chronograph hand : 0.09 μ N·m Minute hand : 0.7 μ N·m
Inertia of hand's moment	1/5 second chronograph hand : less than 0.2 μ g·m ²

5. BATTERY

Type / Size	Silver oxide battery / ϕ 9.5mm × t 2.73mm
Recommended battery	SR927W
Nominal voltage	1.55 V
Battery life	Approx. 3 years
Driving current consumption	Approx. 0.80 μ A
Operation stopping voltage	0.9 V

6. SEPARATED PARTS (Parts code)

Hand setting stem	0351584 (Standard) or 0351585 (Long)
Holding ring for dial	0866854 (Standard)
Battery	SR927W
Magnetic shield plate	4259509
Piezoelectric element	4589801
A.C. comment seal	0110705

7. TEST OF ACCURACY

Equipment to be used	SEIKO quartz tester QT-99, QT2100 Greiner quartz timer-C , Witschi Q-tester 4000
Duration of measurement	10 seconds
Microphone to be used	Electromagnetic detection type

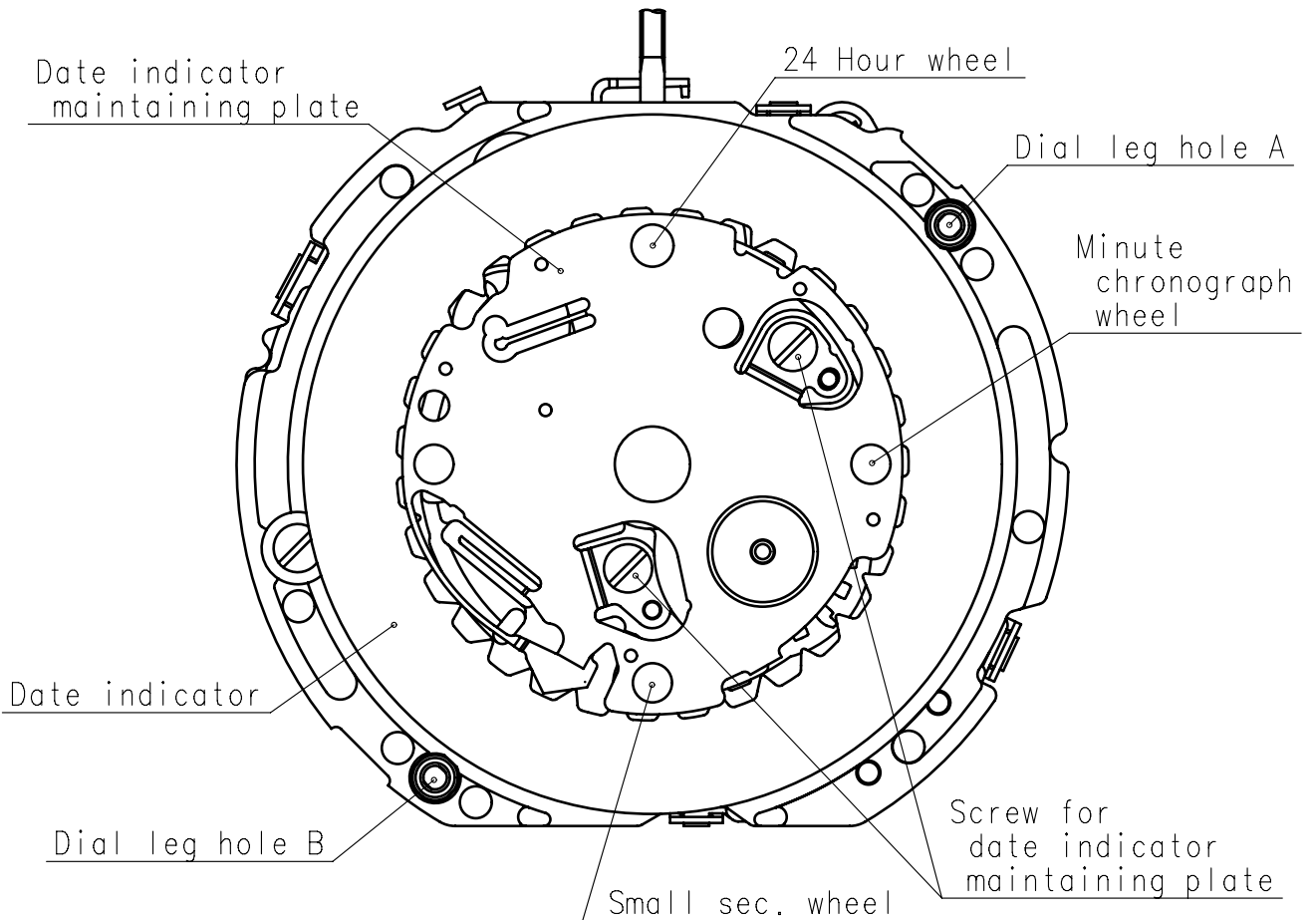
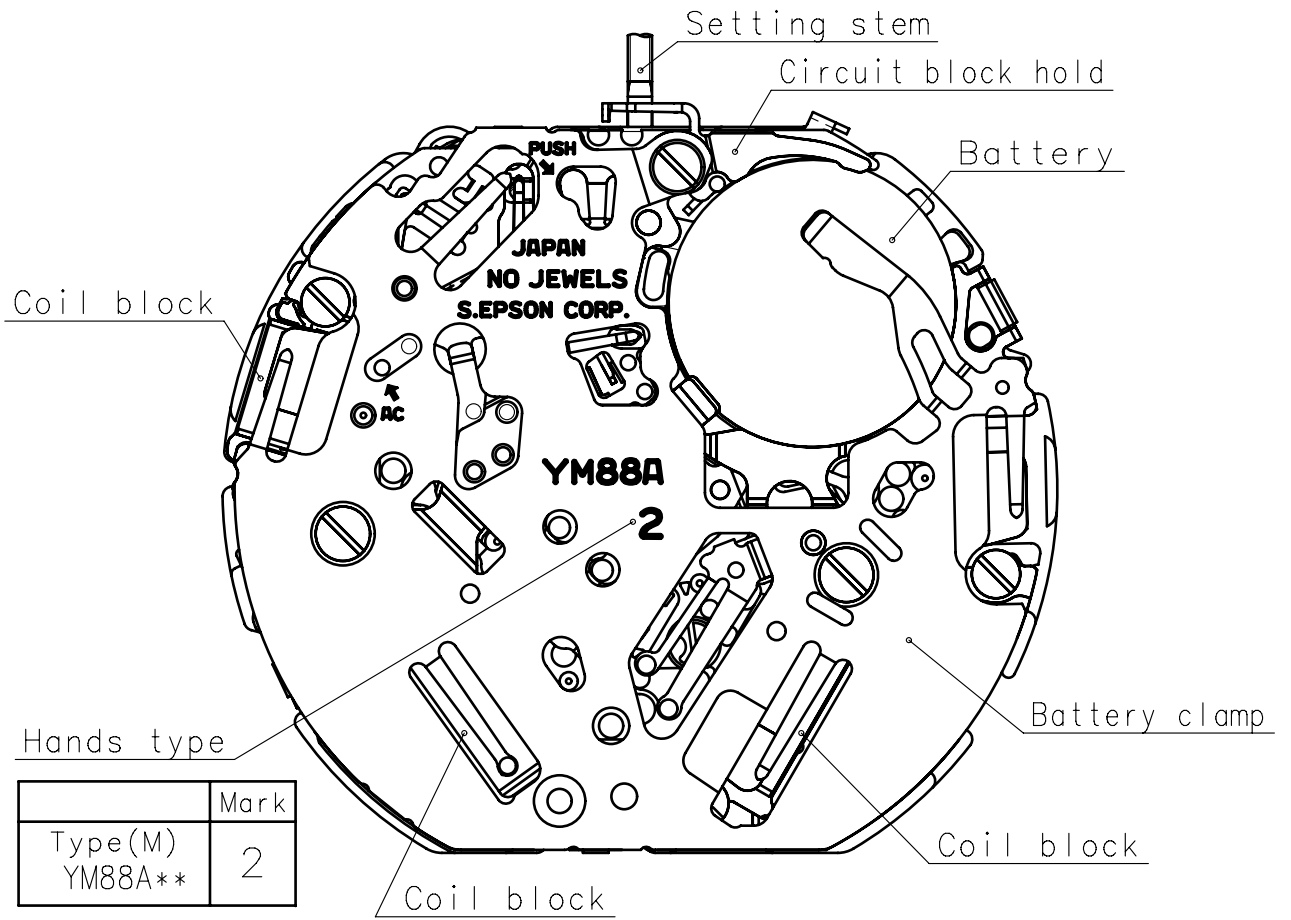

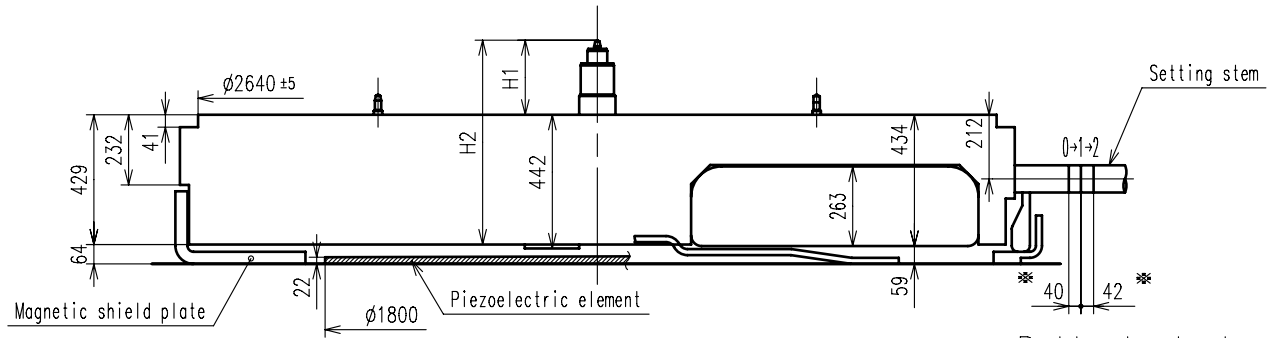

※ Pullout stroke

Center post		Type M (2) YM89A**
Maximum height from dial support	H1	246.5
Total height incl. movement	H2	675.5

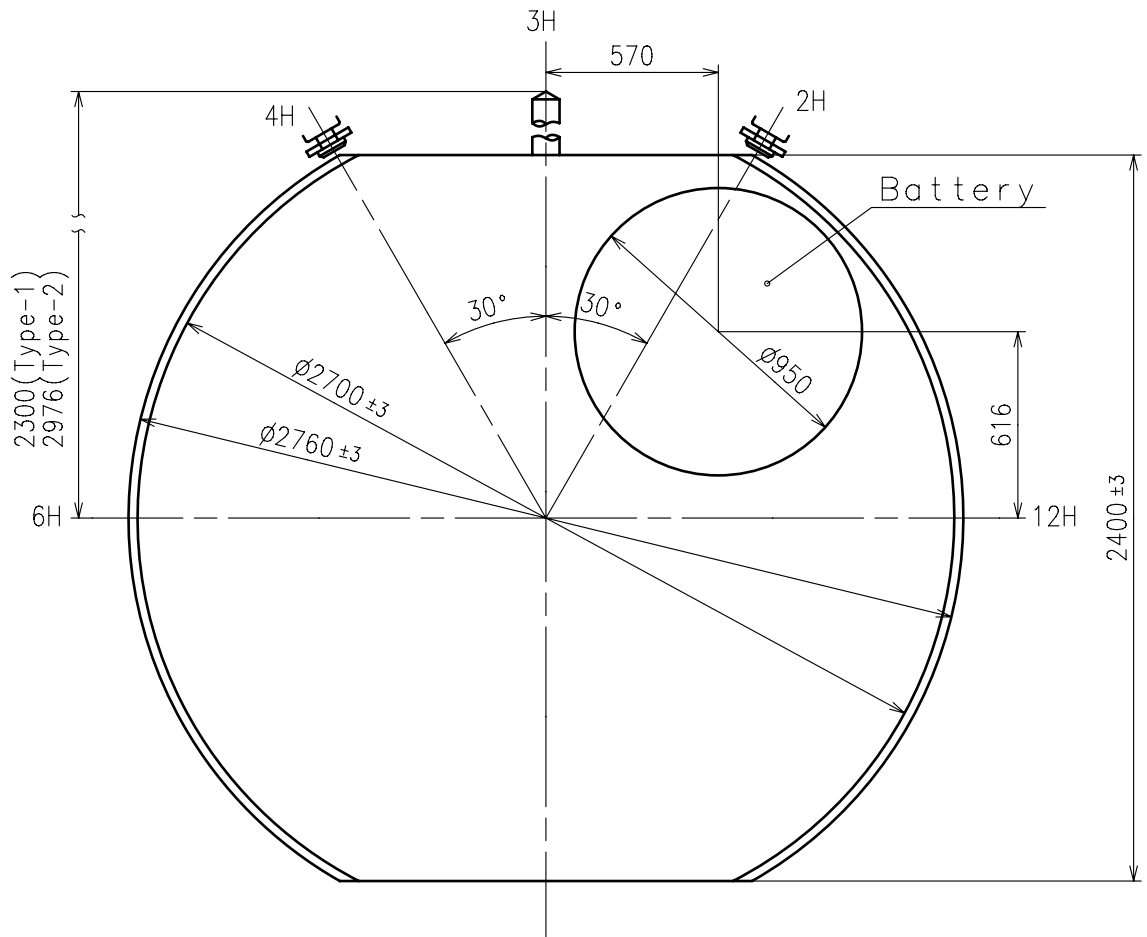
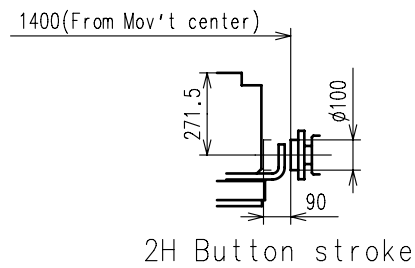
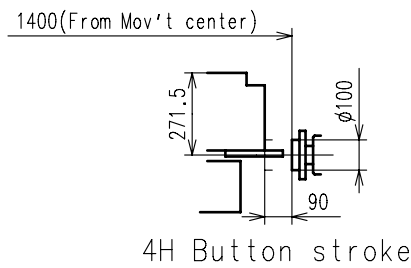

- * Unbalance
 - Small sec. hand $\leq 0.03\mu \text{ N} \cdot \text{m}$ ($3\mu \text{ g} \cdot \text{m}$)
 - 24 Hour hand $\leq 0.03\mu \text{ N} \cdot \text{m}$ ($3\mu \text{ g} \cdot \text{m}$)
 - Minute chronograph hand $\leq 0.03\mu \text{ N} \cdot \text{m}$ ($3\mu \text{ g} \cdot \text{m}$)
 - 1/5 sec. chronograph hand $\leq 0.09\mu \text{ N} \cdot \text{m}$ ($9\mu \text{ g} \cdot \text{m}$)
 - Minute hand $\leq 0.70\mu \text{ N} \cdot \text{m}$ ($70\mu \text{ g} \cdot \text{m}$)
- * Moment of inertia
 - 1/5 sec. chronograph hand $\leq 0.2\mu \text{ g} \cdot \text{m}^2$

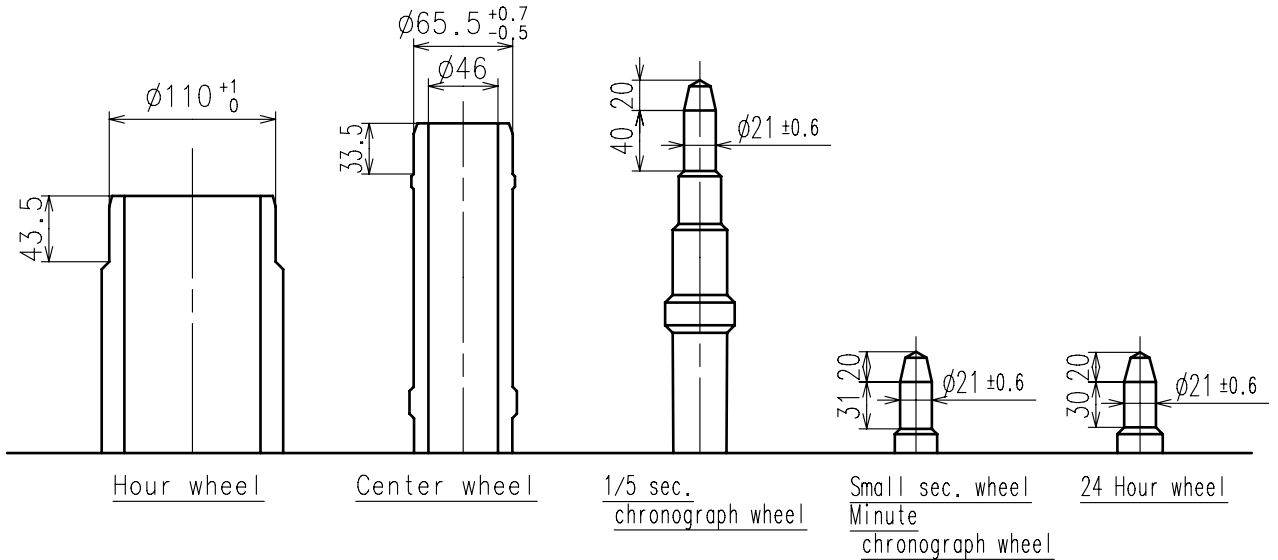

	Parts No.					
	Hour wheel	Center wheel	1/5 sec. chronograph wheel	Small sec. wheel	Minute chronograph wheel	24 Hour wheel
Type M (2) YM88A**	0271637	0221605	0888502	0240512	0902501	1002535

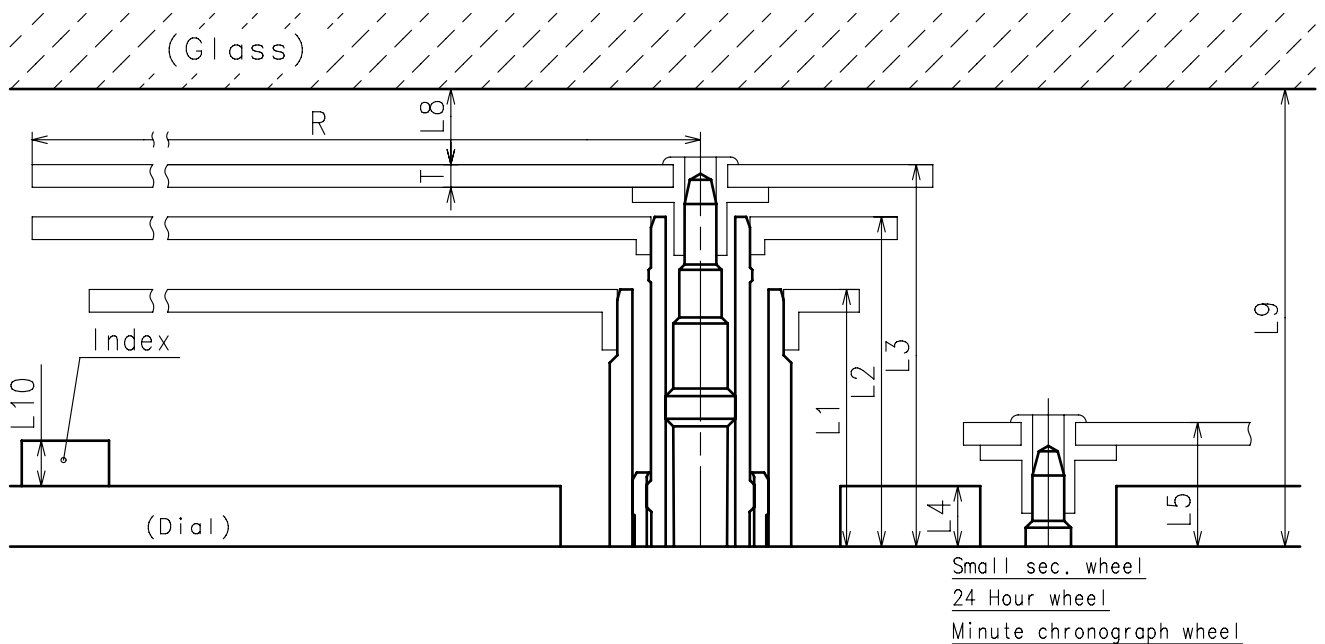

	L1	L2	L3	L4	L5	—	—	L8	L9	L10	T	R
Type M (2) YM88A**	170	218	252.5	40	82	—	—	MIN: 50	MIN: 302.5	MAX: 50	15	MAX: 1250

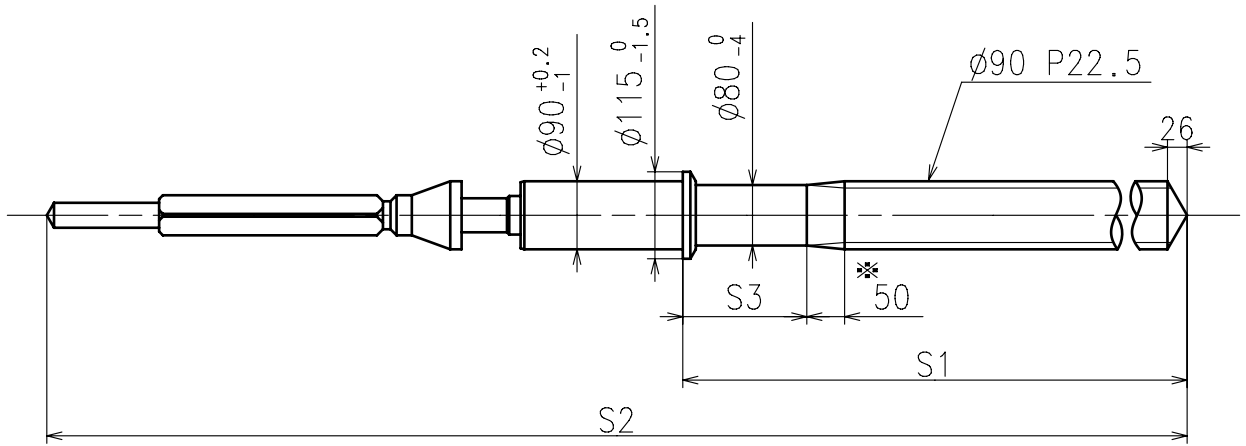

※ Not threaded

	Part No.	S1	S2	S3
Type-1 (Standard)	0351584	1164	2005.5	164
Type-2 (Long)	0351585	1840	2681.5	750

Material : Steel

Hardness : Vickers 600±50

Part No. : 4259509

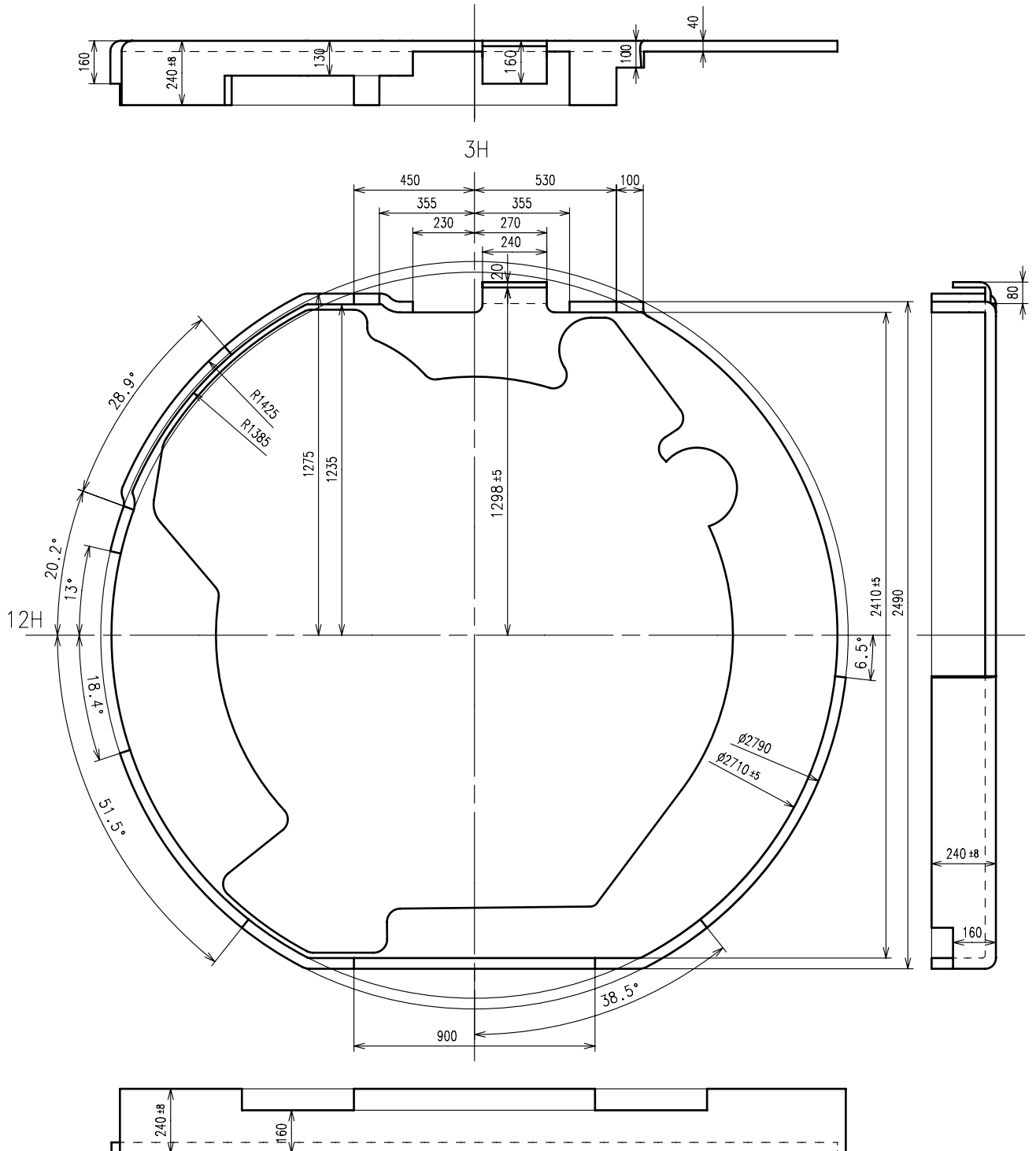

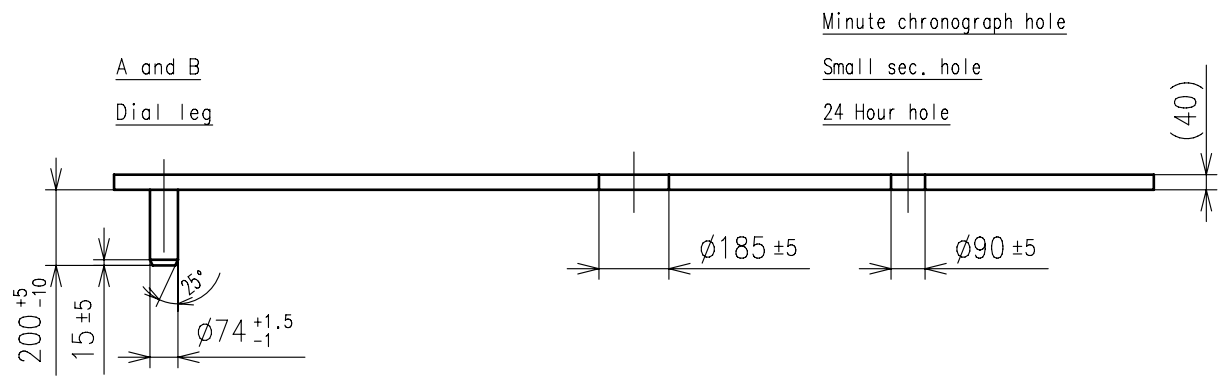
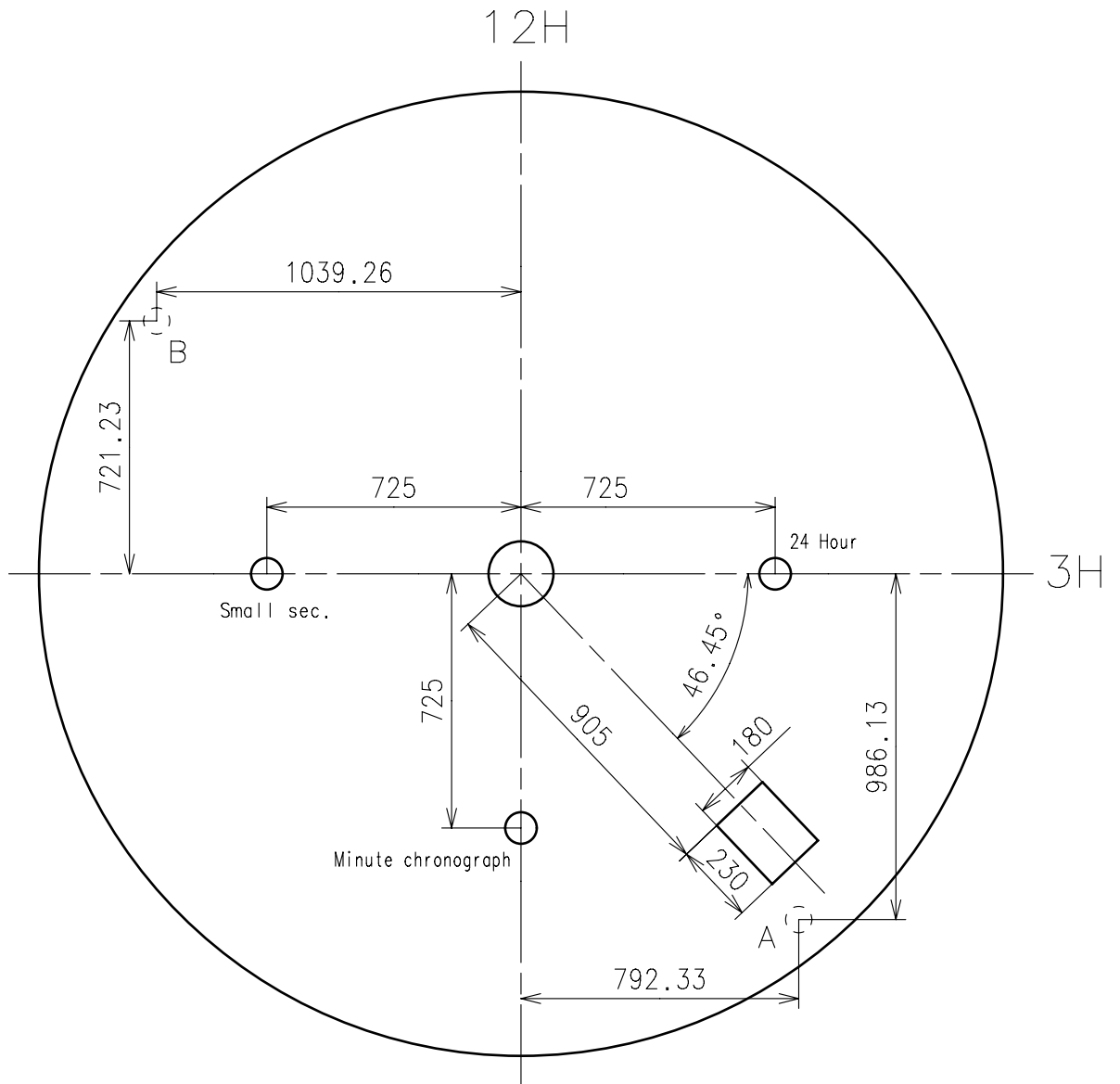

TYPE 1 : STANDARD
PART CODE: 0866854
MOV'T REF: YM88A**

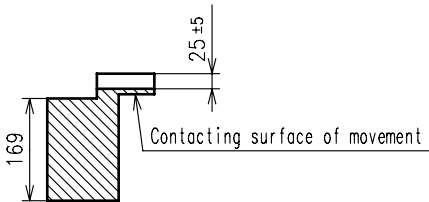
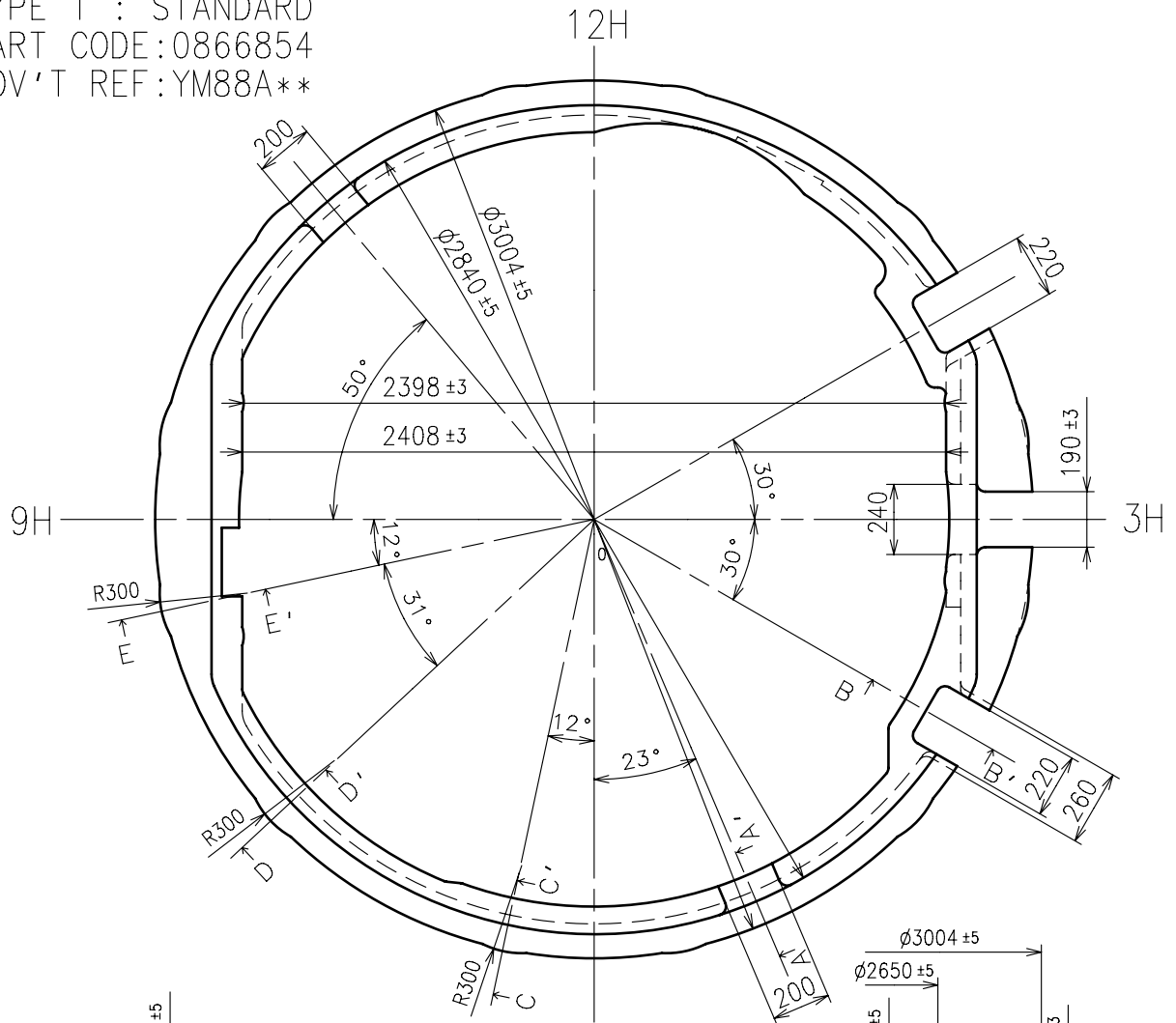

A-A' section

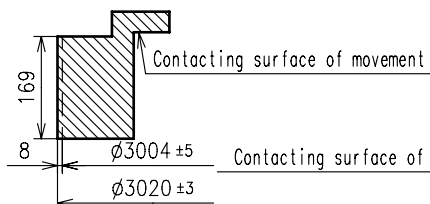

C-C' section

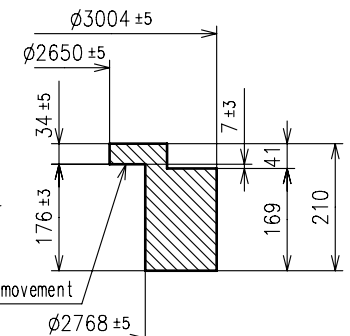

0-12H section

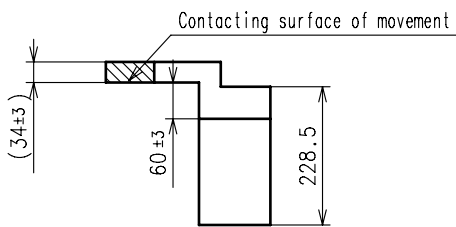

B-B' section

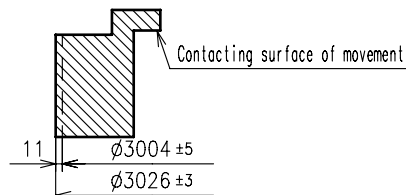

D-D' section

E-E' section

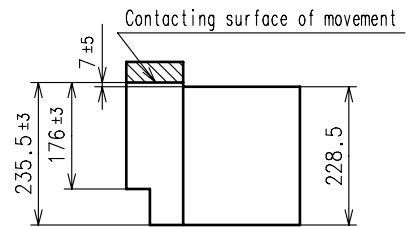

0-3H section

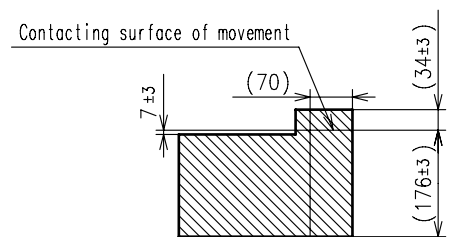

0-9H section

1.How to change the battery

- Please use the exclusive battery to keep the stable performance for a long time.
- Please set the battery with the minus part toward the inside of the watch.
- When you assemble or change the battery, it is recommended to pull out three battery clamp screws first, and then take out the battery clamp in order not to add the damage to the movement part.
- When you assemble the battery without taking out the battery clamp, please refer to the picture in below and set the battery from the [→] direction.
- Regarding the [A] part of the following chart, it is recommended that the battery must be under the circuit holder.
- It is necessary to do system-reset. After assembling the battery, please short the circuit pattern "AC" and the battery clamp for more than 2 seconds.
- Please set the 1/5 second chronograph hand, minute chronograph hand at "0" position.

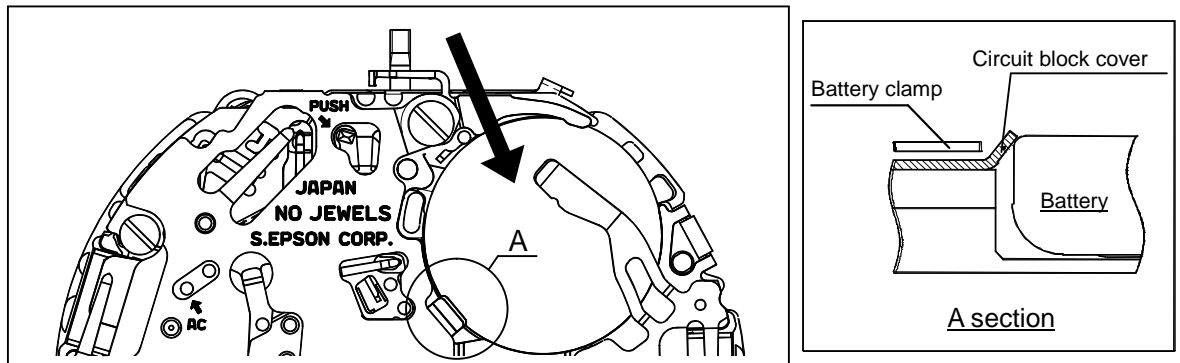

2.How to pull out the stem

- Please pull out the crown at 1st click and then pull out the stem while you are pressing the hollow part of the setting lever by tweezers. If the stem is not at 1st position, it is impossible to be pulled out.

(Crown pulled out at 1st click)

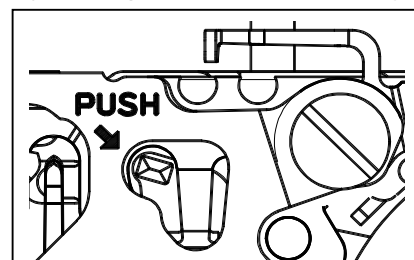

3.Attention to set each hand

- Hand moves at one-second interval. Please set the each hand at correct position according to the scale of the dial in order not to make a mistake.
- Please do not turn the hour hand forcibly.

4.How to take off the hand

- When you take off the hand, please use the fork-shaped exclusive tools.
- Please do not take off the dial when any hands are assembled.

5.How to test the accuracy

- Measure the timing with Quartz Tester in 10 second's gate.

1.Minute hand

- In order not to push the minute hand too much, the second wheel have a safety stopper structure. However, please pay attention for the friction between hour hand and minute hand.

2.Casing ring

- Please use the exclusive casing ring to fix the movement tightly inside of the case, and to stabilize the button switching stroke. As to the shape and tolerance, please refer to the [Casing ring] page instruction.

3.Case

- Please use the metal case to prevent movement from being mal-functioned by static electricity.

4.Magnetic shield plate

- Please set the Anti-magnetic plate B above the movement (battery clamp) before assembling the Case back. So as to don't mistake assembling direction, please refer to the [Magnetic shield plate] page instruction.

5.A.C. comment seal

- Please attach the A.C. comment seal to the center of the Case back.

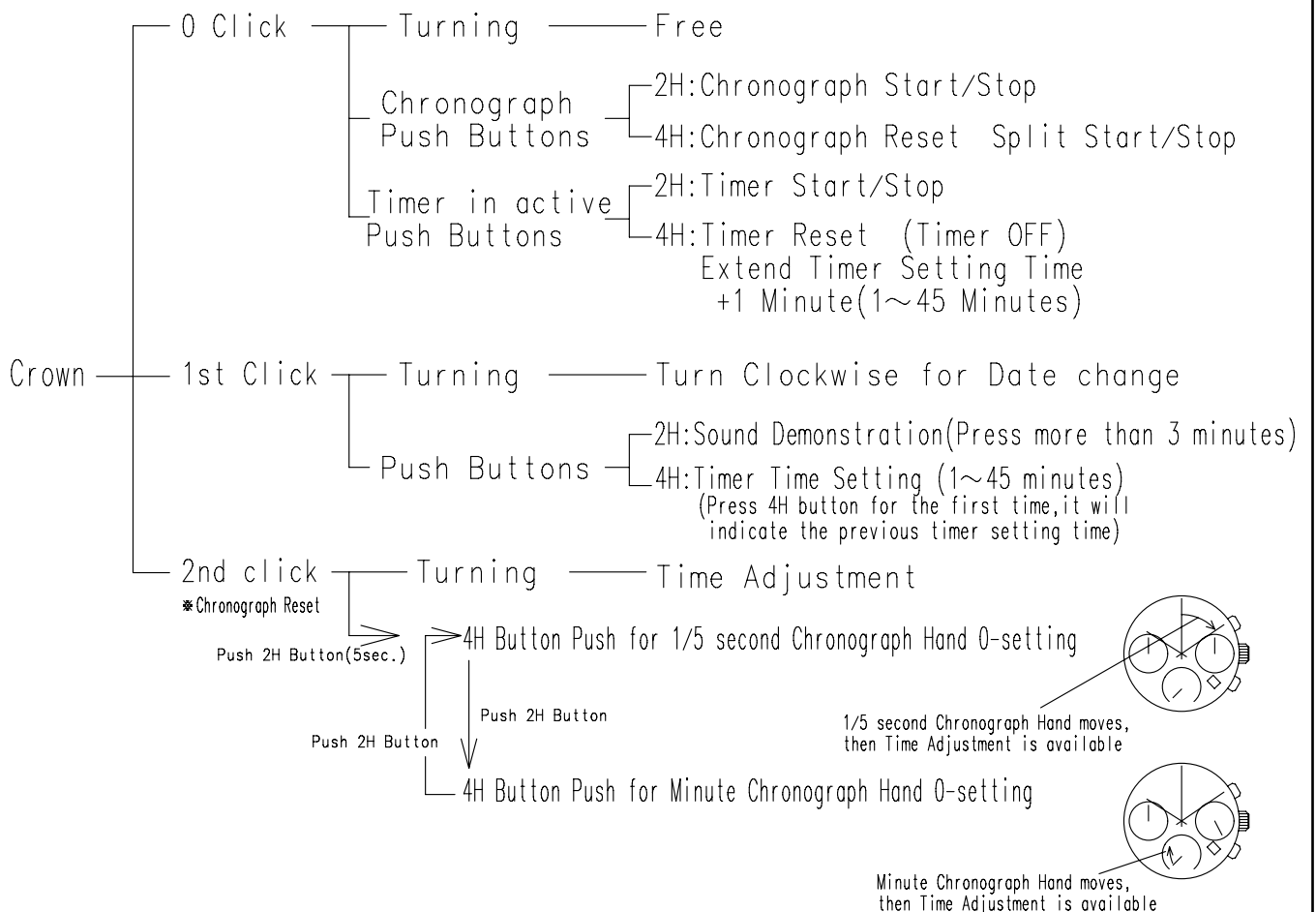
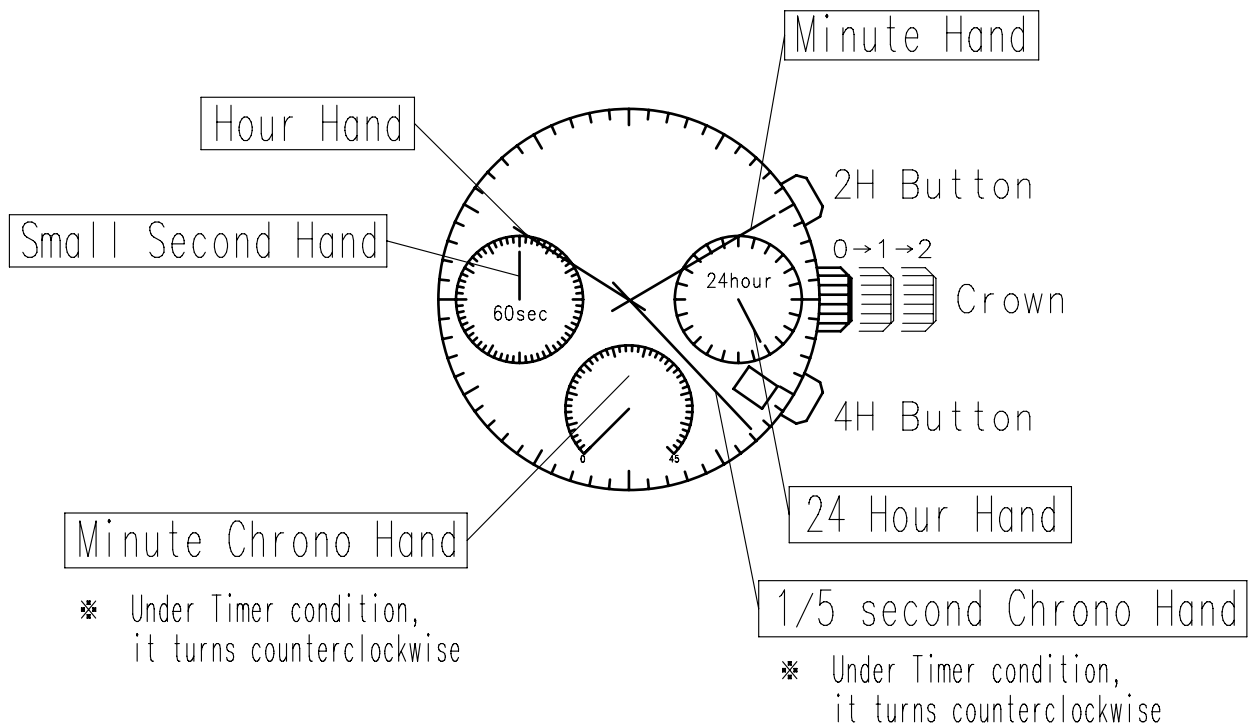

At 2nd click position, system-reset is possible by pushing the 2H button and 4H button for more than 2 seconds simultaneously.

Chronograph Operation					
Total Time	START	STOP			RESET
Accumulated Time	START	STOP	RESTART	STOP	RESET
Split Time	START	SPLIT	RESPLIT	STOP	RESET

Chronograph will be stopped automatically after 45 minutes counting.
At that time, the 1/5 second chronograph hand stops at 0 position and the minute chronograph hand stops at 45 minute position.

If the time elapse 45 minutes while measuring split time, the split function will be released.
The 1/5 second chronograph hand will stop at 0 position and minute chronograph hand will stop at 45 minute position.

After stop counting automatically, press 4H button for 0 position reset.

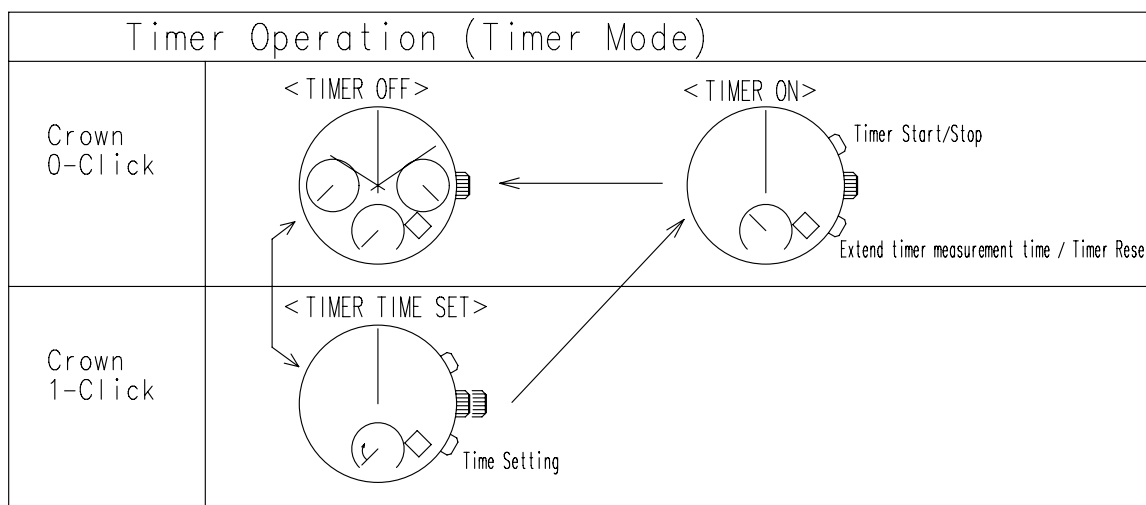

After measuring timer, timer setting will be reset and it will be ready for chronograph.

Under the Timer Time Set condition, press 4H button for the first time, it will indicate the previous time setting time.