



Cal. YM64A

ϕ 27.0 mm
H 4.34 mm

Items	Rev.	Page
Specifications	00	1
Appearance	00	2
Casing	01	3
Hand fitting	00	4
Hand setting stem	01	5
Dial	00	6
Casing ring	00	7
Attention for assembly	00	8
Casing instructions	01	9
Operation-01	00	10-01
Operation-02	00	10-02

Date: 26/Dec./'11

S.EPSON Products

CAL. YM64A

Analog Quartz 12''' Center second Chronograph and Alarm Movement

1. MOVEMENT DIMENSIONS

Outside diameter	ϕ 27.60mm (12H-6H) × 24.00mm (3H-9H)
Casing diameter	ϕ 27.00mm (12H-6H)
Total height	4.34mm (including battery)

2. TIME STANDARD

Type of quartz oscillator	Tuning fork
Frequency of quartz oscillator	32,768 Hz
Accuracy	±20 seconds per month (on wrist)
Operating temperature range	-5°C to +50°C
Regulation device	Nil (Pre-adjusted)

3. INDICATOR / FUNCTIONS

3 Hands	Hour hand / Minute hand / 1/5second chronograph hand (Center)
Small hands	Alarm hour and minute hand (6H) / Small second hand (9H)
	Minute chronograph hand (12H) / 24 Hour hand (3H)
Calendar	Instant setting device for date calendar
Reset switch	
Alarm	
Power depletion warning function (BLD)	
(Small second hand moves at 2-second intervals)	
Setting mechanism	Crown at normal position : Free
	Crown pulled out 1st click : Instant date change
	Crown pulled out 2nd click : Time setting / Reset
	: Chronograph hand reset
Stopwatch	2H button: start / stop
	4H button: sprit / reset

4. FEATURES

Jewels	0 Jewel
Anti-magnetism	Over 1600A/m (Direct current magnetic field)
Maximum unbalance of hands	Small second hand / Alarm minute hand : 0.03 μ N·m
	24 Hour hand / Minute chronograph hand : 0.03 μ N·m
	1/5 second chronograph hand : 0.09 μ N·m
	Minute hand : 0.7 μ N·m
Inertia of hand's moment	1/5 second chronograph hand : less than 0.2 μ g·m ²

5. BATTERY

Type / Size	Silver oxide battery / ϕ 9.5mm × t 2.73mm
Recommended battery	SR927W
Nominal voltage	1.55 V
Battery life	Approx. 3 years
Driving current consumption	Approx. 0.80 μ A
Operation stopping voltage	0.9 V

6. SEPARATED PARTS (Parts code)

Hand setting stem	0351584 (Standard) or 0351585 (Long)
Holding ring for dial	0866854 (Standard)
Battery	SR927W
Piezoelectric element	4589801

7. TEST OF ACCURACY

Equipment to be used	SEIKO quartz tester QT-99, QT2100 Greiner quartz timer-C , Witschi Q-tester 4000
Duration of measurement	10 seconds
Microphone to be used	Electromagnetic detection type

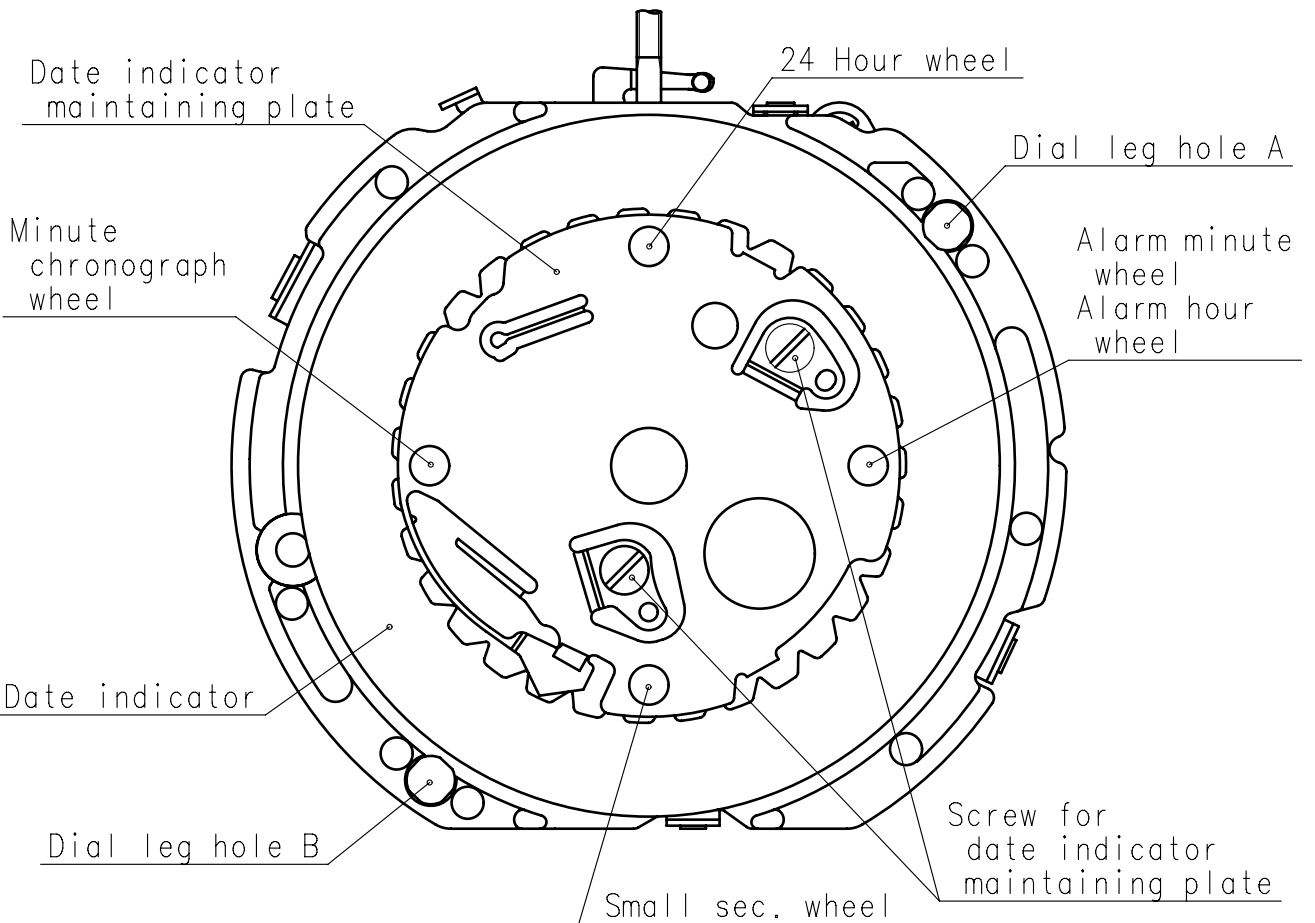
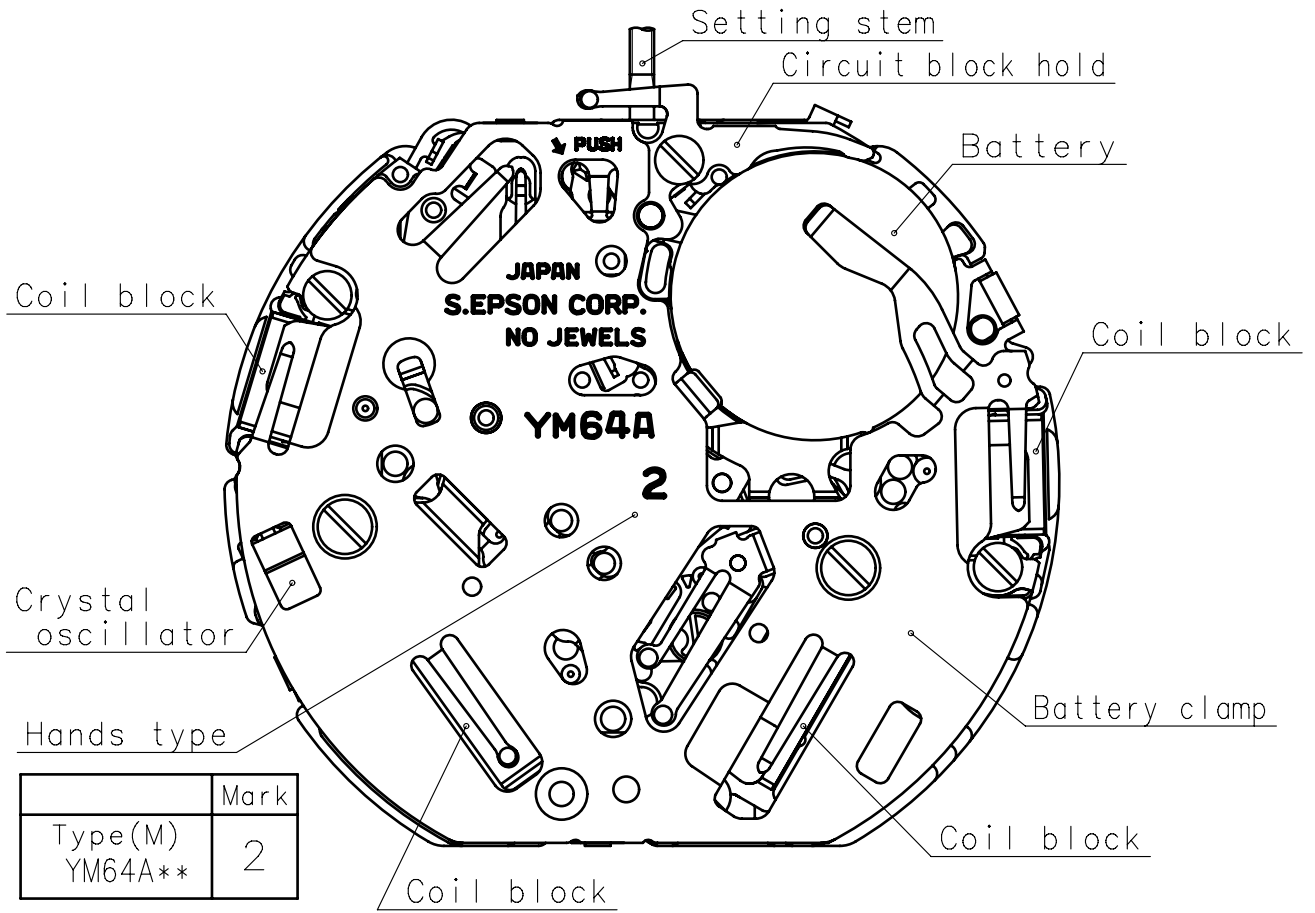

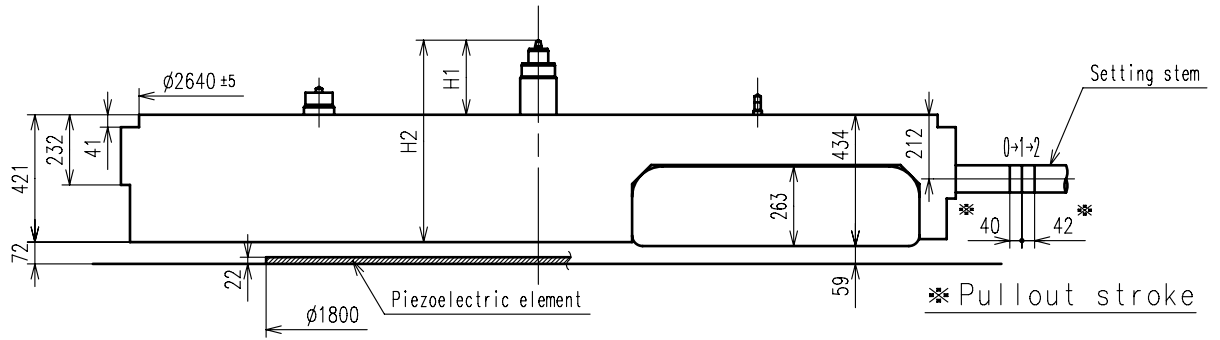

Center post		Type M (2) YM64A**
Maximum height from dial support	H1	246.5
Total height incl. movement	H2	667.5

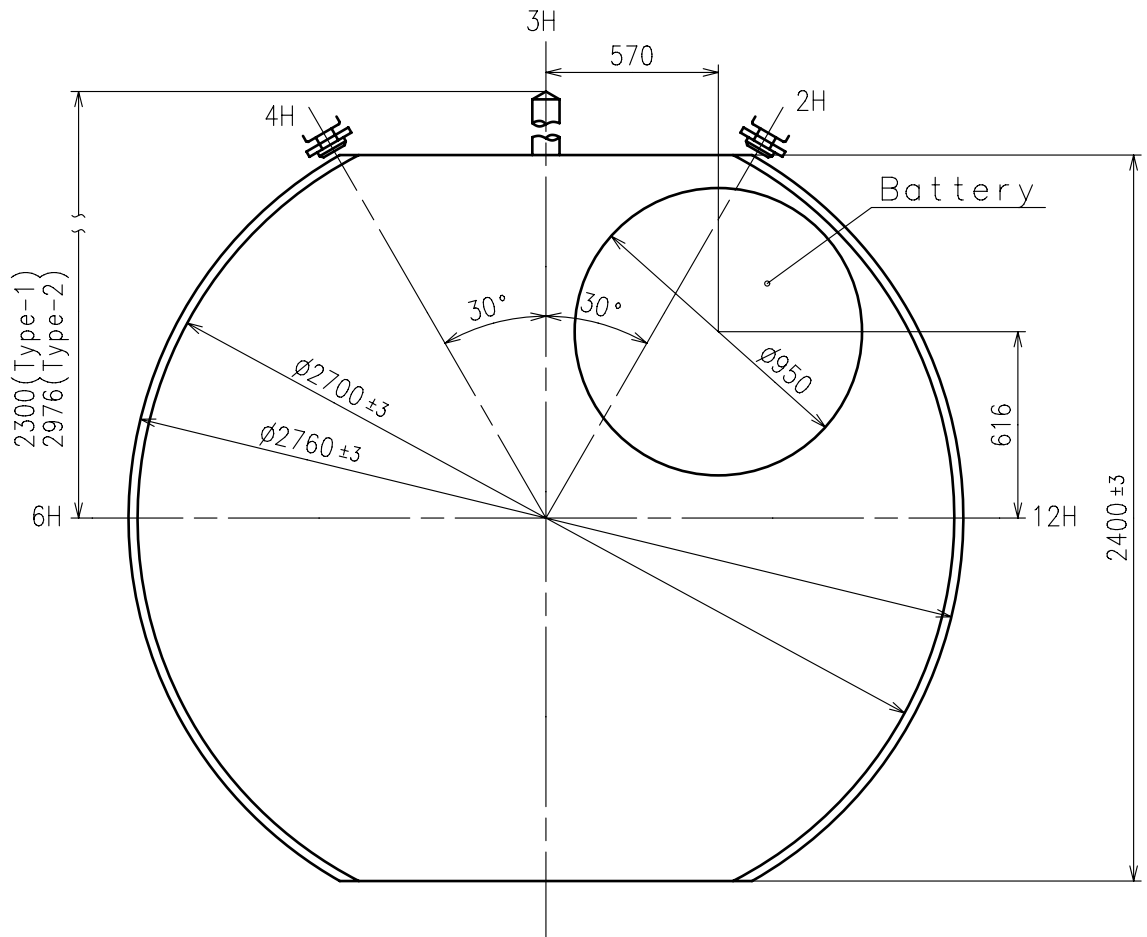
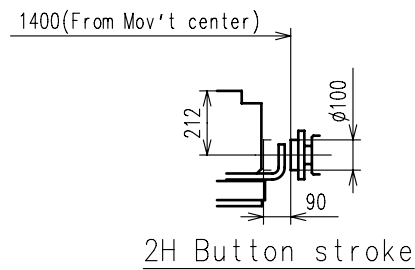
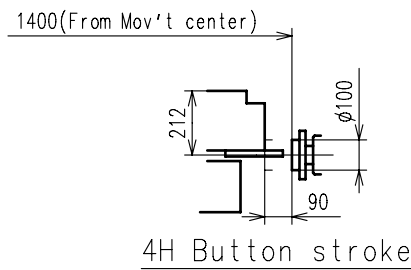

※ Unbalance

- Small sec. hand $\leq 0.03\mu\text{ N}\cdot\text{m}$ ($3\mu\text{ g}\cdot\text{m}$)
- 24 Hour hand $\leq 0.03\mu\text{ N}\cdot\text{m}$ ($3\mu\text{ g}\cdot\text{m}$)
- Alarm minute hand $\leq 0.03\mu\text{ N}\cdot\text{m}$ ($3\mu\text{ g}\cdot\text{m}$)
- Minute chronograph hand $\leq 0.03\mu\text{ N}\cdot\text{m}$ ($3\mu\text{ g}\cdot\text{m}$)
- 1/5 sec. chronograph hand $\leq 0.09\mu\text{ N}\cdot\text{m}$ ($9\mu\text{ g}\cdot\text{m}$)
- Minute hand $\leq 0.70\mu\text{ N}\cdot\text{m}$ ($70\mu\text{ g}\cdot\text{m}$)

※ Moment of inertia

- 1/5 sec. chronograph hand $\leq 0.2\mu\text{ g}\cdot\text{m}^2$

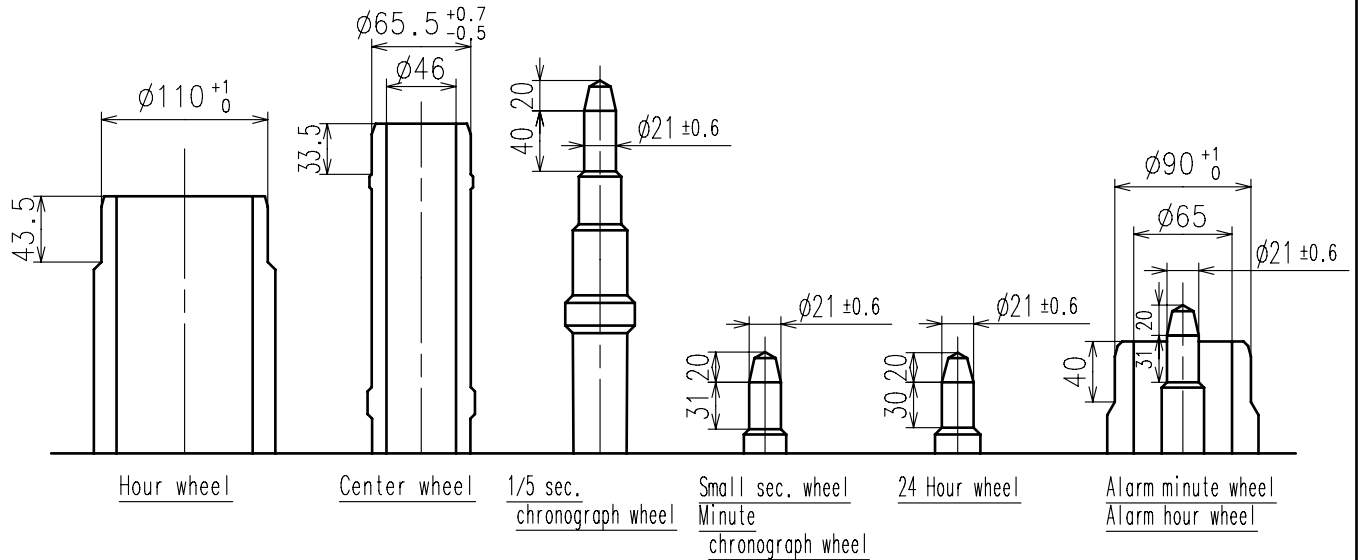

	Parts No.							
	Hour wheel	Center wheel	1/5 sec. chronograph wheel	Small sec. wheel	Minute chronograph wheel	24 Hour wheel	Alarm minute wheel	Alarm hour wheel
Type M (2) YM64A**	0271637	0221605	0888502	0240512	0902501	1002535	0902503	0271640

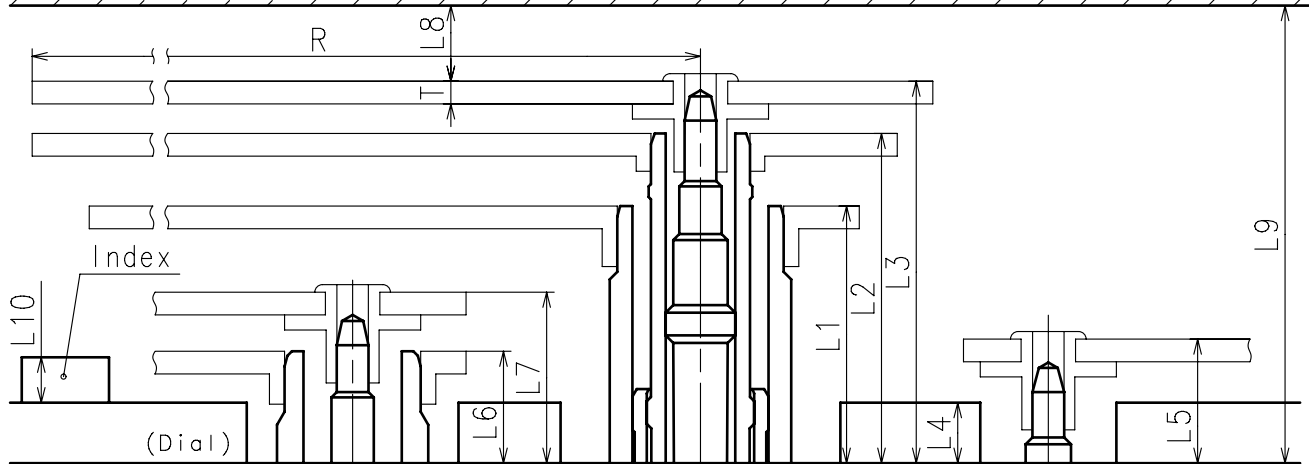

Alarm minute wheel
Alarm hour wheel

Small sec. wheel
24 Hour wheel
Minute chronograph wheel

	L1	L2	L3	L4	L5	L6	L7	L8	L9	L10	T	R
Type M (2) YM64A**	170	218	252.5	40	82	77	127	MIN: 50	MIN: 302.5	MAX: 50	15	MAX: 1250

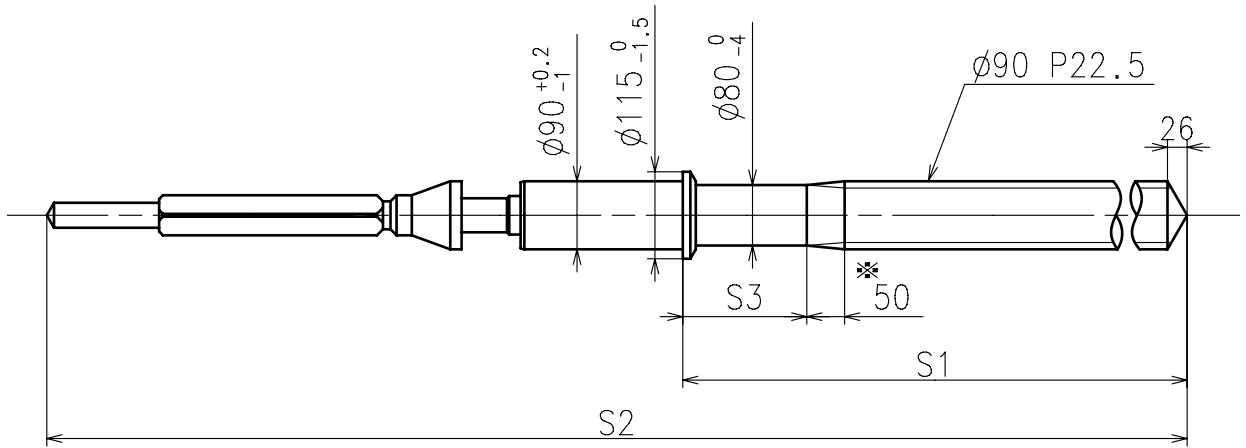

※ Not threaded

	Part No.	S1	S2	S3
Type-1 (Standard)	0351584	1164	2005.5	164
Type-2 (Long)	0351585	1840	2681.5	750

Material : Steel

Hardness : Vickers 600±50

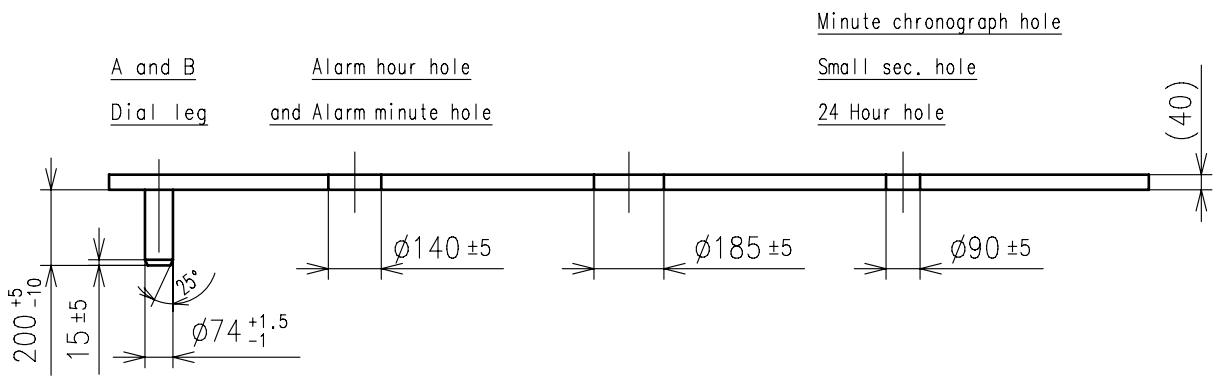
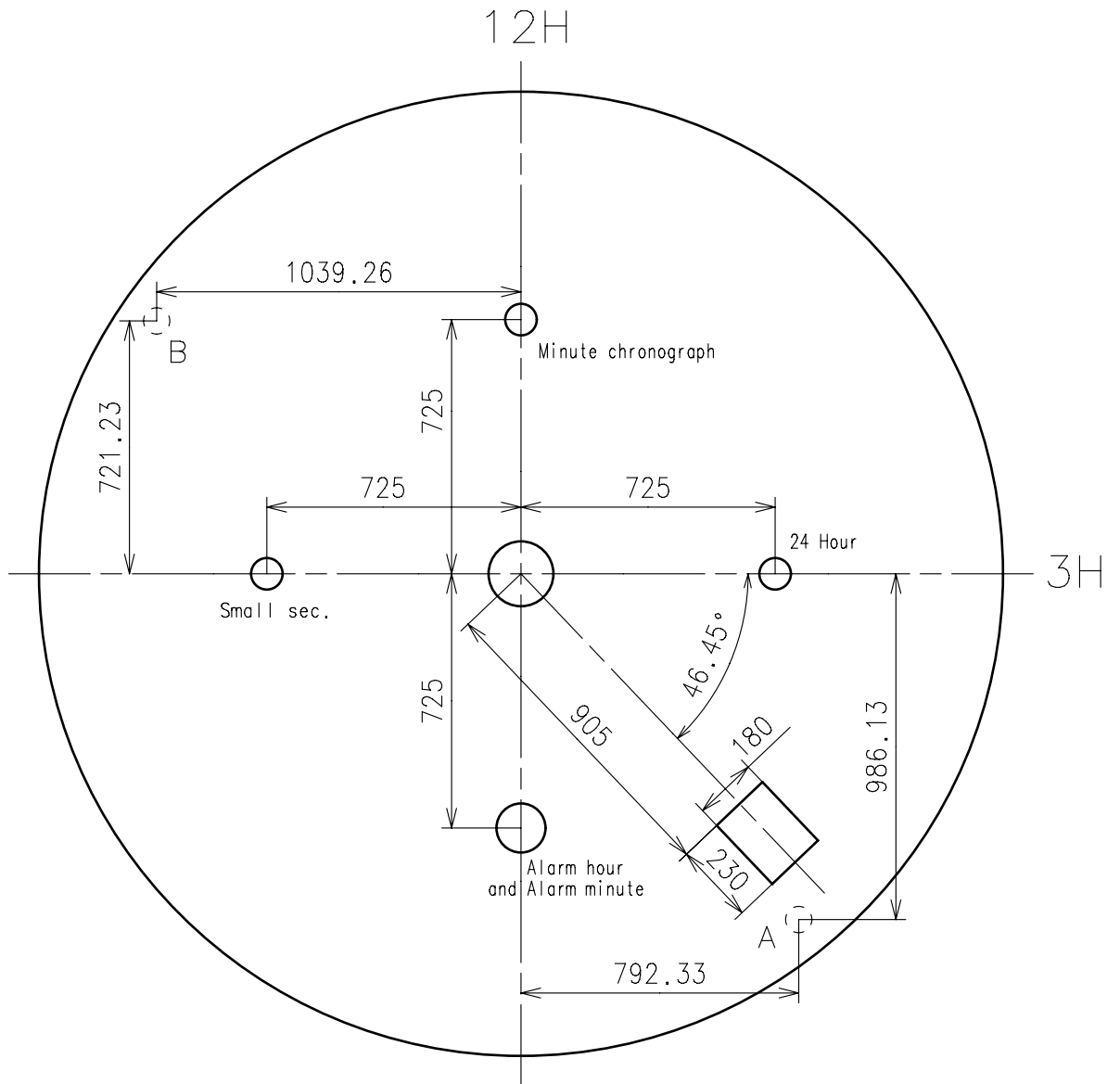

TYPE 1 : STANDARD
PART CODE: 0866854
MOV'T REF: YM64A**

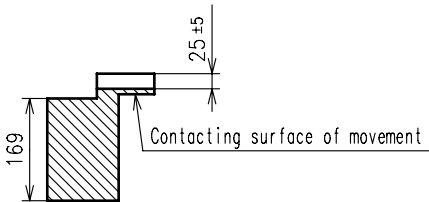
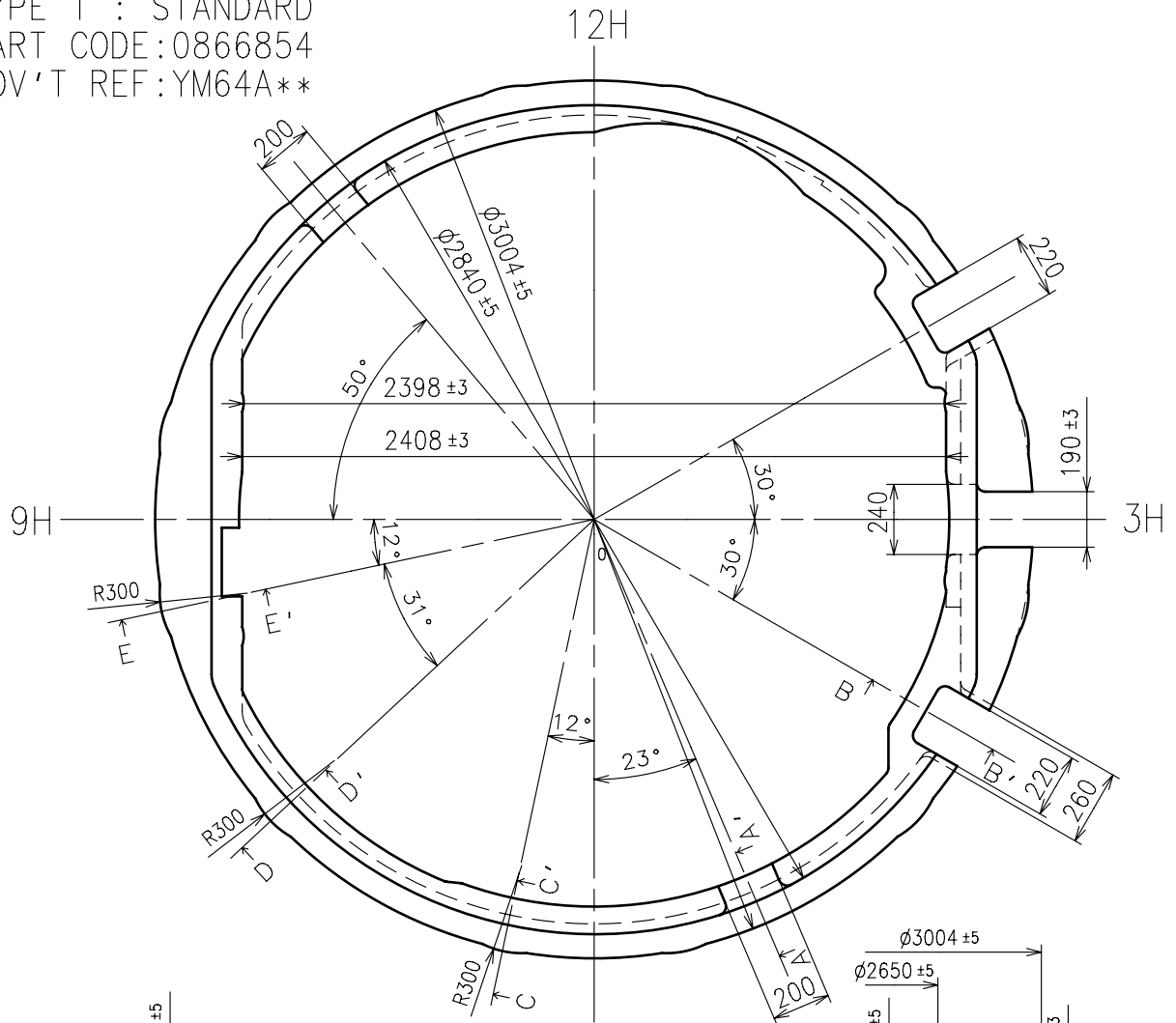

A-A' section

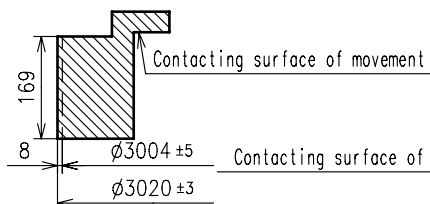

C-C' section

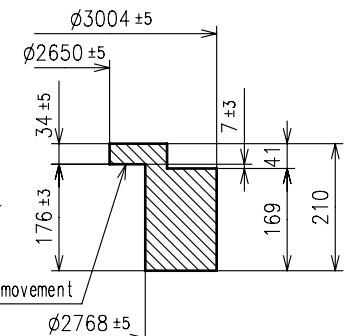

0-12H section

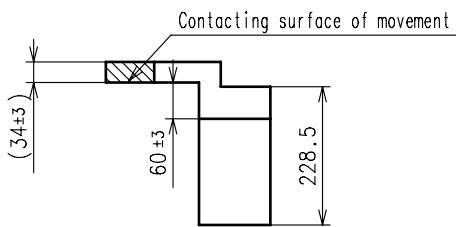

B-B' section

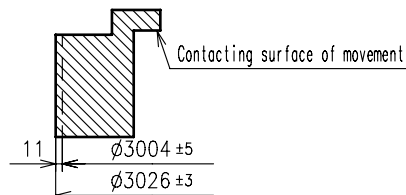

D-D' section

E-E' section

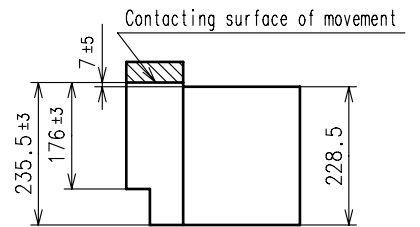

0-3H section

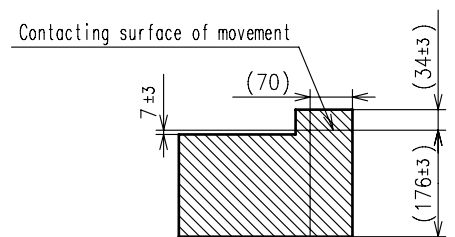

0-9H section

1.How to change the battery

- Please use the exclusive battery to keep the stable performance for a long time.
- Please set the battery with the minus part toward the inside of the watch.
- When you assemble or change the battery, it is recommended to pull out two battery clamp screws first, and then take out the battery clump in order not to add the damage to the movement part.
- When you assemble the battery without taking out the battery clamp, please refer to the picture in below and set the battery from the [→] direction.
- Regarding the [A] part of the following chart, it is recommended that the battery must be under the circuit holder.
- It is not necessary to do system-reset.
- After the battery is changed, please set the current time first, and then set the alarm time at current time too, in order to let the alarm work correctly.
- Please set the 1/5 second CG hand and minute CG hand at 12H position.

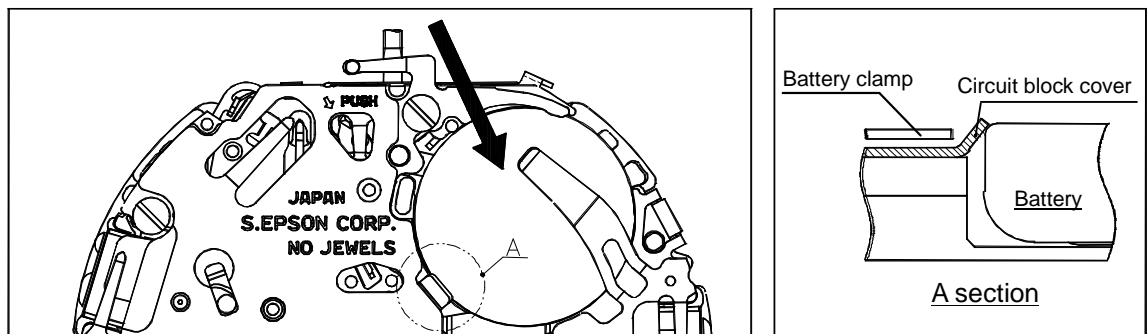

2.How to pull out the stem

- Please pull out the crown at 1st click and then pull out the stem while you are pressing the hollow part of the setting lever by tweezers. If the stem is not at 1st position, it is impossible to be pulled out.

(Crown pulled out at 1st click)

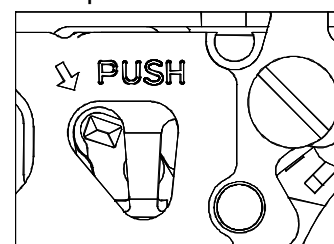

3.Attention to set each hand

- Hand moves at one-second interval. Please set the each hand at correct position according to the scale of the dial in order not to make a mistake.
- Please do not turn the hour hand forcibly.

4.How to take off the hand

- When you take off the hand, please use the fork-shaped exclusive tools.
- Please do not take off the dial when any hands are assembled.

5.How to test the accuracy

- Measure the timing with Quartz Tester in 10 second's gate.

YM64 Attention of casing part structure

Date: 24/Dec./'10

Rev.: 01

1.Minute hand

- In order not to push the minute hand too much, the second wheel have a safety stopper structure. However, please pay attention for the friction between hour hand and minute hand.

2.Casing ring

- Please use the exclusive casing ring to fix the movement tightly inside of the case, and to stabilize the button switching stroke. As to the shape and tolerance, please refer to the [Casing ring] page instruction.

3.Case

- Please use the metal case to prevent movement from being mal-functioned by static electricity.

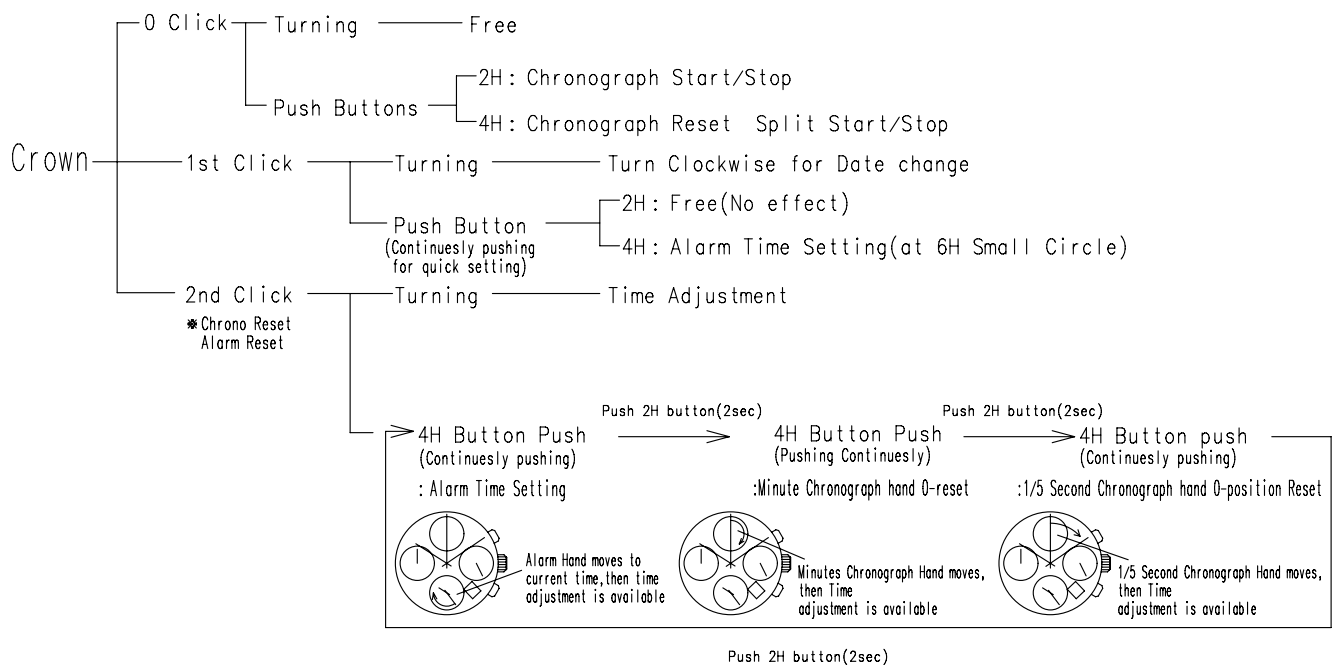
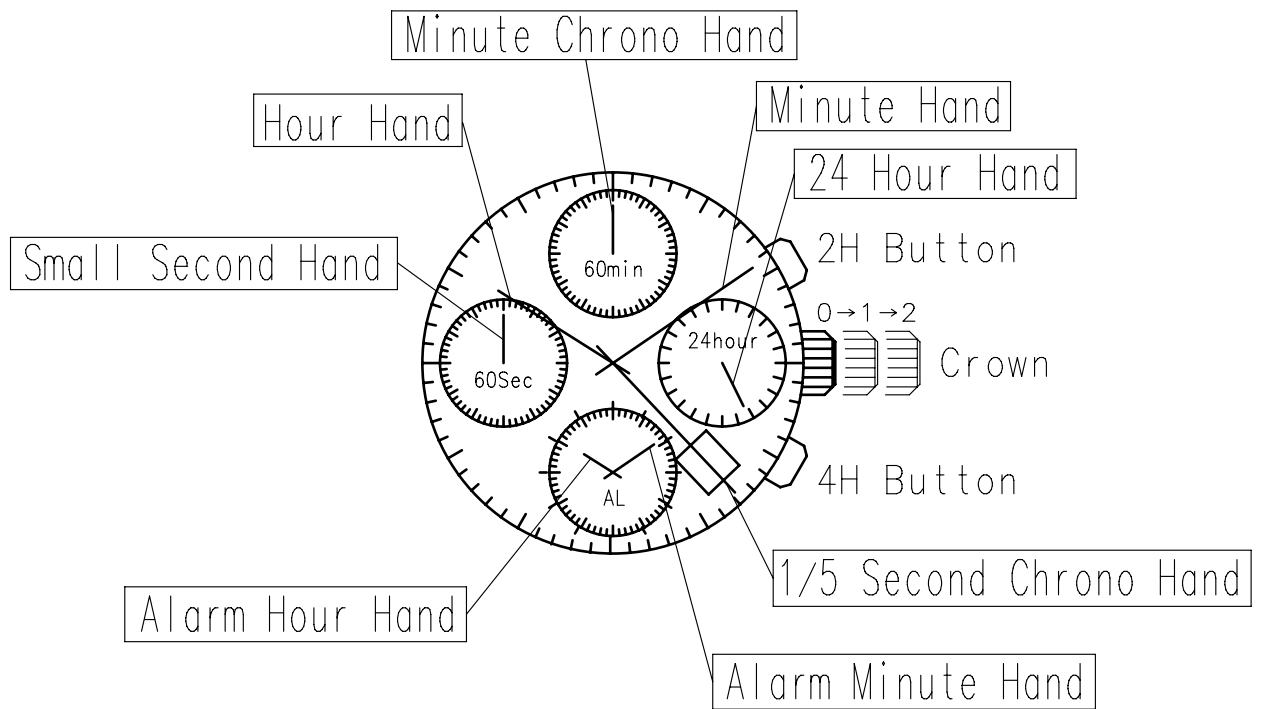

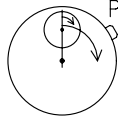
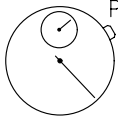
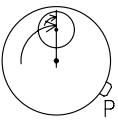
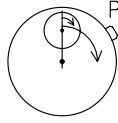
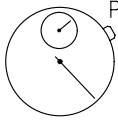
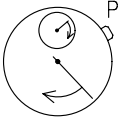
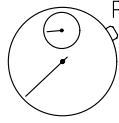
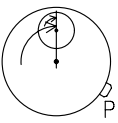
Chronograph Operation (Crown 0-Click)					
Total Time	START	STOP			RESET
					
Accumulated Time	START	STOP	RESTART	STOP	RESET
					
Split Time	START	SPLIT	RESPLIT	STOP	RESET
	