



# Cal. VX3MA

$\phi$  23.3 mm  
H 3.05 mm

Items	Rev.	Page
Specifications	01	1
Appearance	00	2
Casing	01	3
Hand fitting	04	4
Hand setting stem	00	5
Dial	00	6
Casing ring	00	7

Date: 15/Sep/'09

S.EPSON Products

## MOVEMENT SPECIFICATIONS

CAL. VX3M

Analog Quartz 10 1/2" Slim Movement / 3 hands (H/M/S) and 3 eyes  
with Day / Date / 24H Rotary Disc ( Sun & Moon ) indicators

## 1. MOVEMENT DIMENSIONS

*Outside diameter	$\phi$ 24.00mm $\times$ 21.50mm(3-9H) $\times$ 22.10mm(12-6H)
*Casing diameter	$\phi$ 23.30mm $\times$ 21.30mm(3-9H) $\times$ 21.50mm(12-6H)
*Total height	3.05mm ( including battery )

## 2. TIME STANDARD

*Type of quartz oscillator	Tuning fork
*Frequency of quartz oscillator	32,768 Hz
*Accuracy	$\pm$ 20 seconds per month ( on wrist )
*Operating temperature range	-5°C to +50°C
*Regulation device	Nil ( Pre-adjusted )

## 3. INDICATOR / FUNCTIONS

*3 Hands	Hour / Minute / Second
*2 Small hands	Day / Date
*24H Rotary Disc	Sun & Moon indication
*Reset switch	
*Setting mechanism	Crown at normal position : Free Crown pulled out 1st click : Instant date change Crown pulled out 2nd click : Time setting ( Day change ) / Reset

## 4. FEATURES

*Jewels	1 Jewel
*Anti-magnetism	Over 1600A/m ( Direct current magnetic field )
*Maximum unbalance of hands	Second hand : 6 mg $\cdot$ mm Minute hand : 65 mg $\cdot$ mm

## 5. BATTERY

*Type / Size	Silver oxide battery / $\phi$ 9.5mm $\times$ t 1.6mm
*Recommended battery	SR916SW ( Maxell, Panasonic, Sony, Seizaiken )
*Nominal voltage	1.55 V
*Battery life	Approx. 3 years
*Driving current consumption	Approx. 0.85 $\mu$ A
*Operation stopping voltage	0.9 V

## 6. SEPARATED PARTS (Parts code)

*Hand setting stem	0354531 or 0354534
*Battery	SR916SW

## 7. TEST OF ACCURACY

*Equipment to be used	SEIKO quartz tester QT-99, Greiner quartz timer-C , Witschi Q-tester 4000
*Duration of measurement	10 seconds
*Microphone to be used	Electromagnetic detection type

All specifications are subject to change without notice.

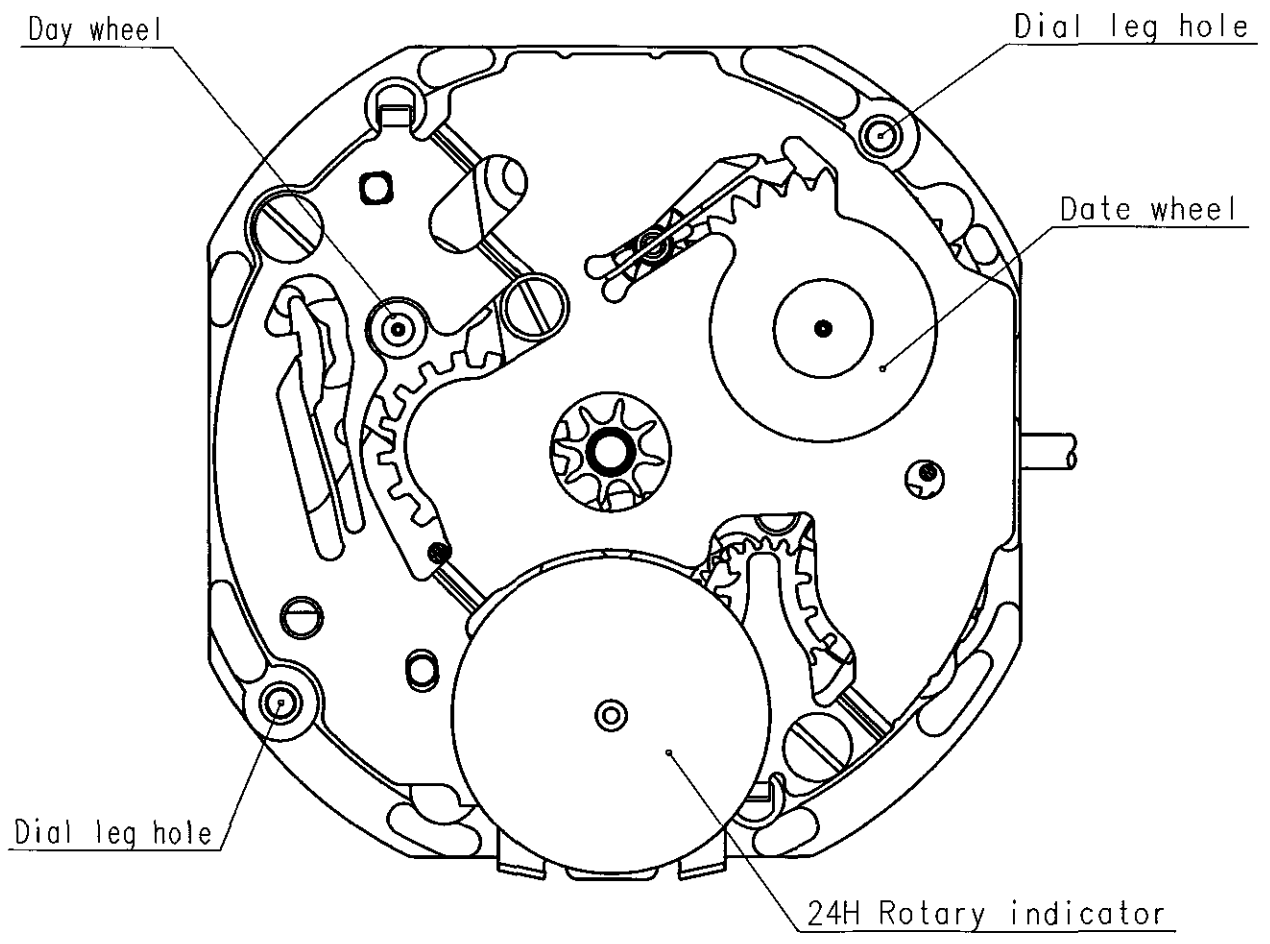
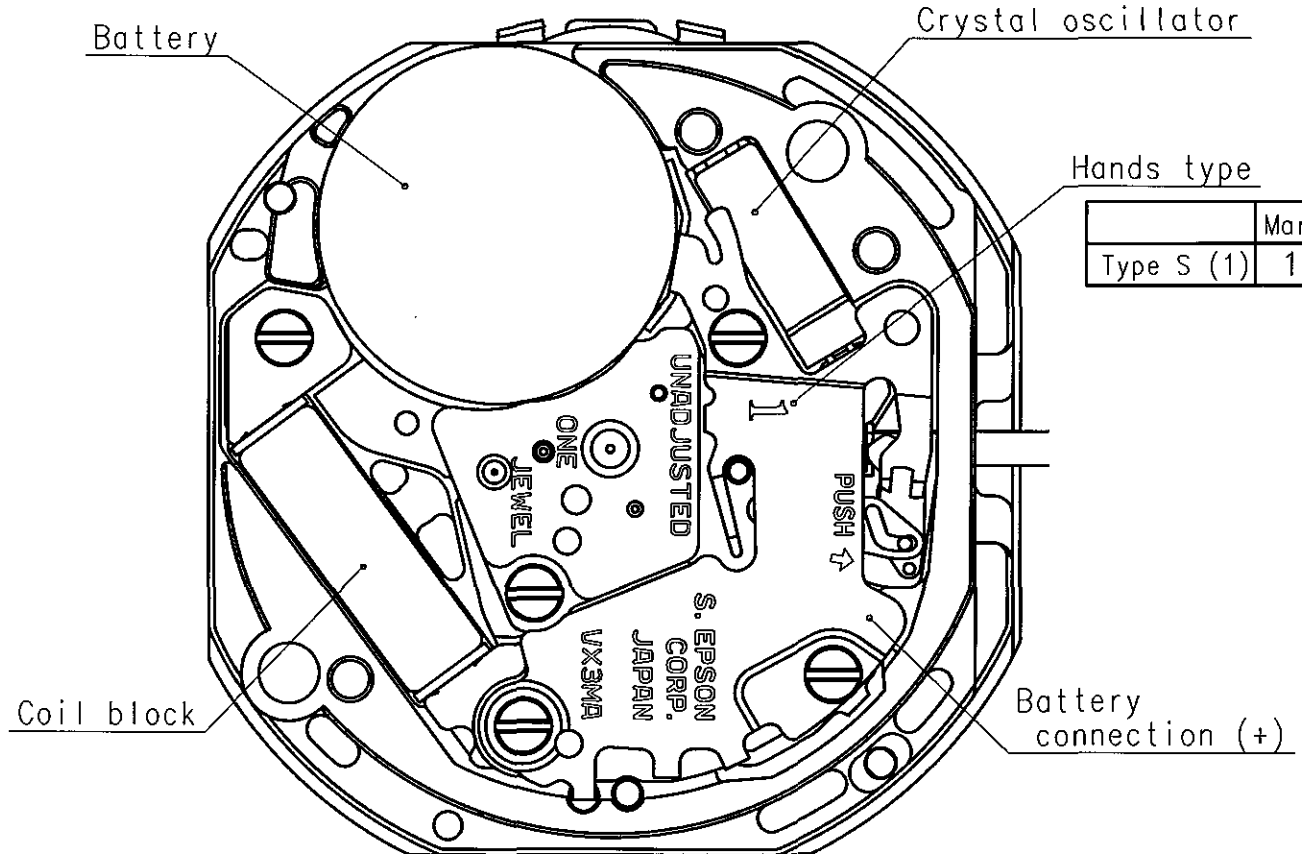

\*1: First pullout stroke

\*2: Second pullout stroke

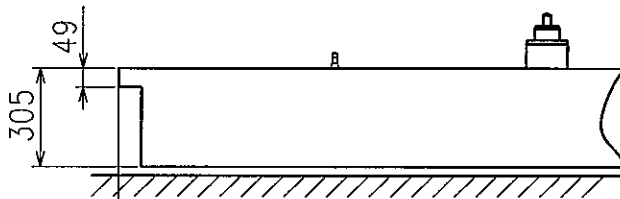
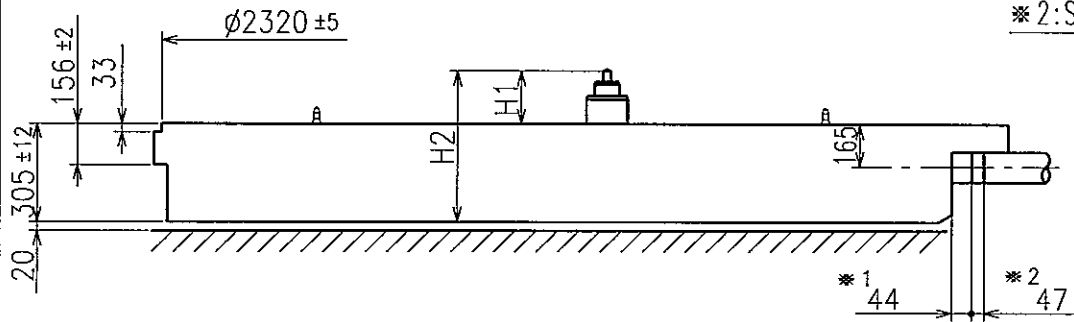

Center post		Type S (1) VX3MA1
Maximum height from dial support	H1	180
Total height incl. movement	H2	500

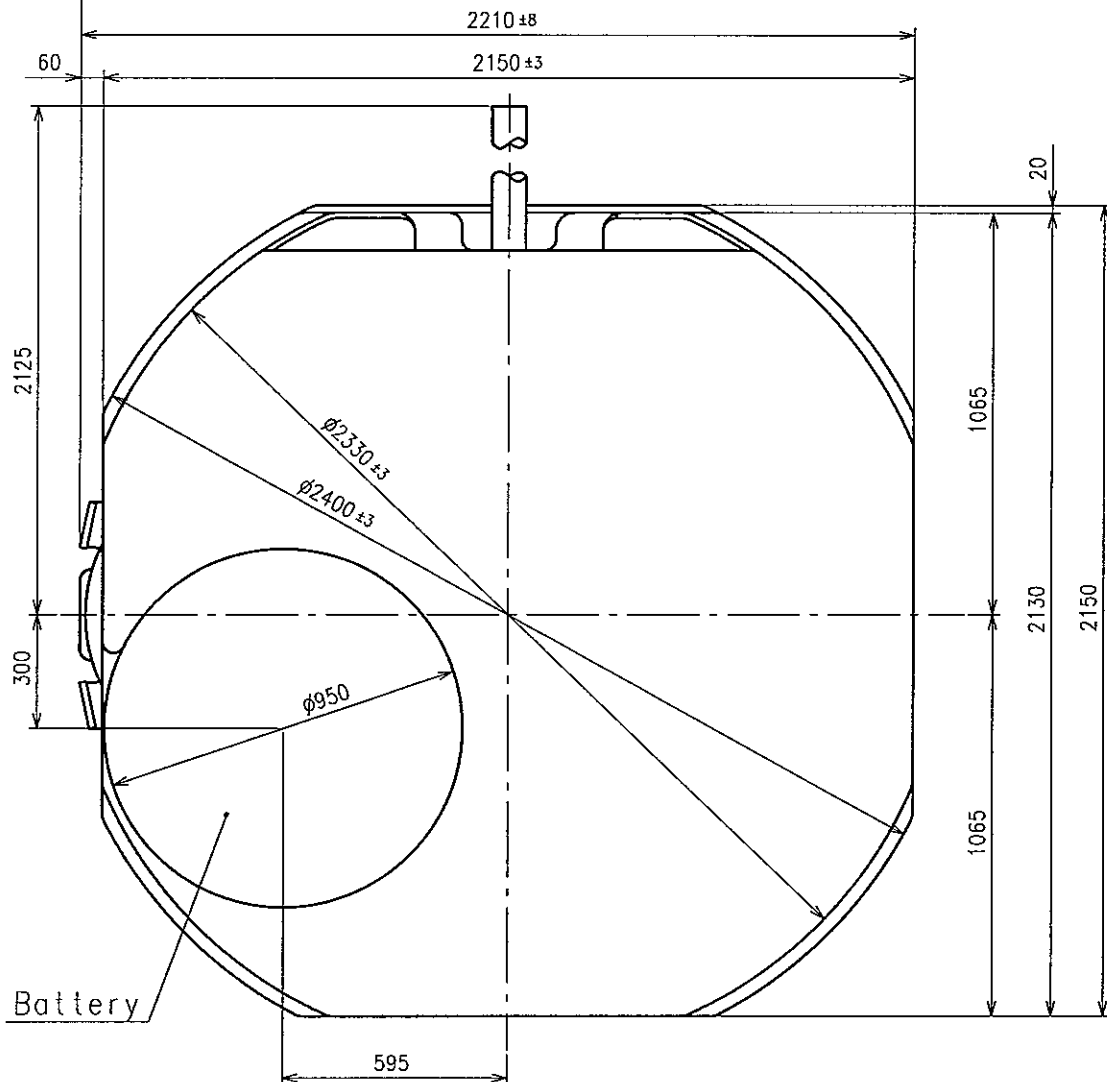

- \* Minute hand unbalance  $\leq 65 \mu\text{g} \cdot \text{m} (0.64 \mu\text{N} \cdot \text{m})$
- \* Second hand unbalance  $\leq 6 \mu\text{g} \cdot \text{m} (0.06 \mu\text{N} \cdot \text{m})$

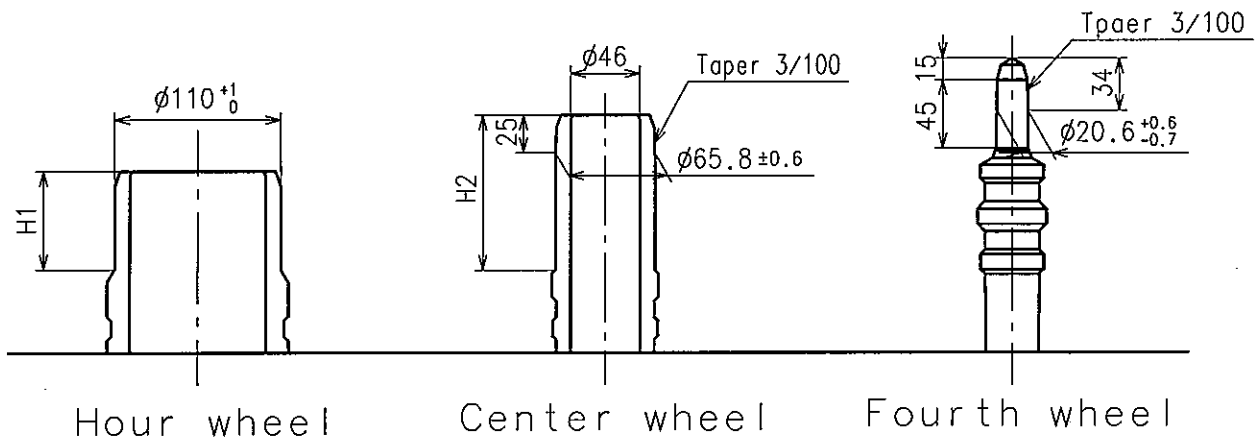

	Parts No.			Dimension	
	Hour wheel	Center wheel	Fourth wheel	H1	H2
Type S (1) VX3MA1	0271538	0221537	0241537	65	103

Date wheel  
Day wheel

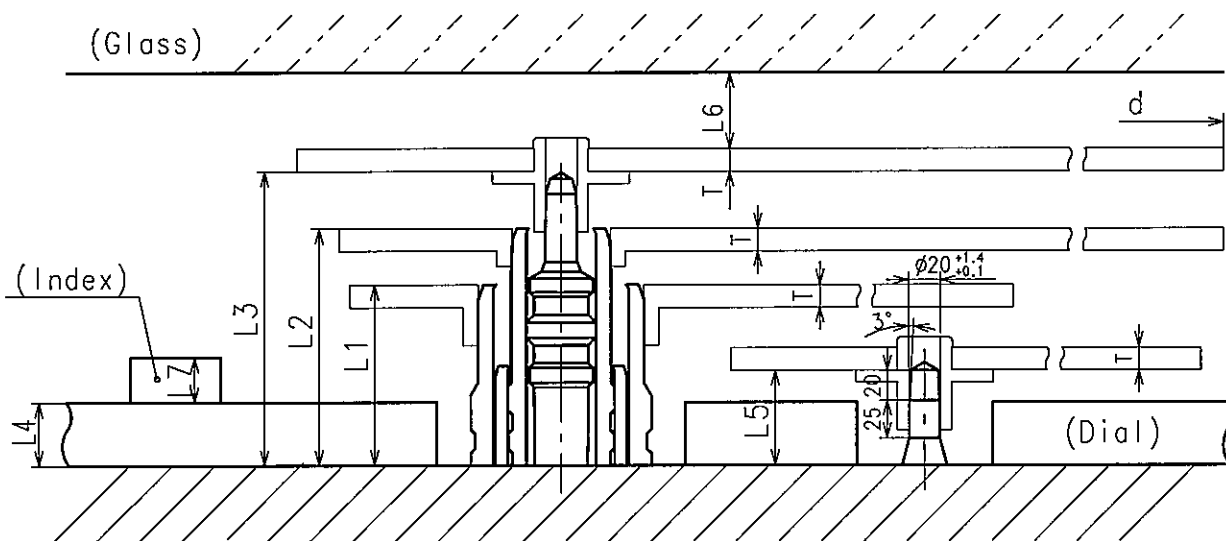

	L1	L2	L3	L4	L5	L6	L7	T	d
Type S (1) VX3MA1	120	157	180	40	63	MIN: 50	MAX: 30	15	MAX: $\phi 2500$

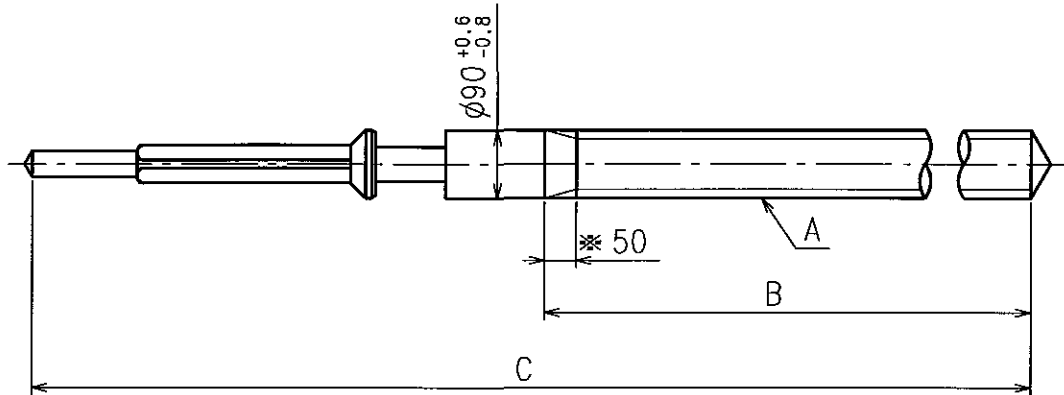

\* Not threaded

	Part No.	A	B	C
Standard Type 1	0354531	$\phi 90$ P22.5	1225	1904
Type 2	0354534	$\phi 90$ P22.5	1500	3055

Material : Steel

Hardness : Vickers  $600 \pm 50$

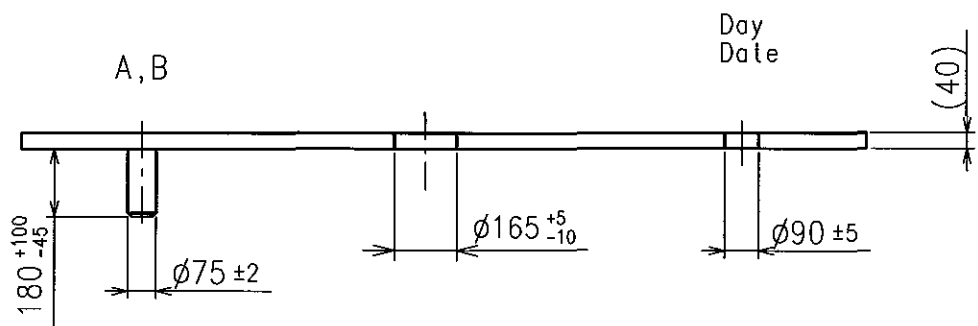
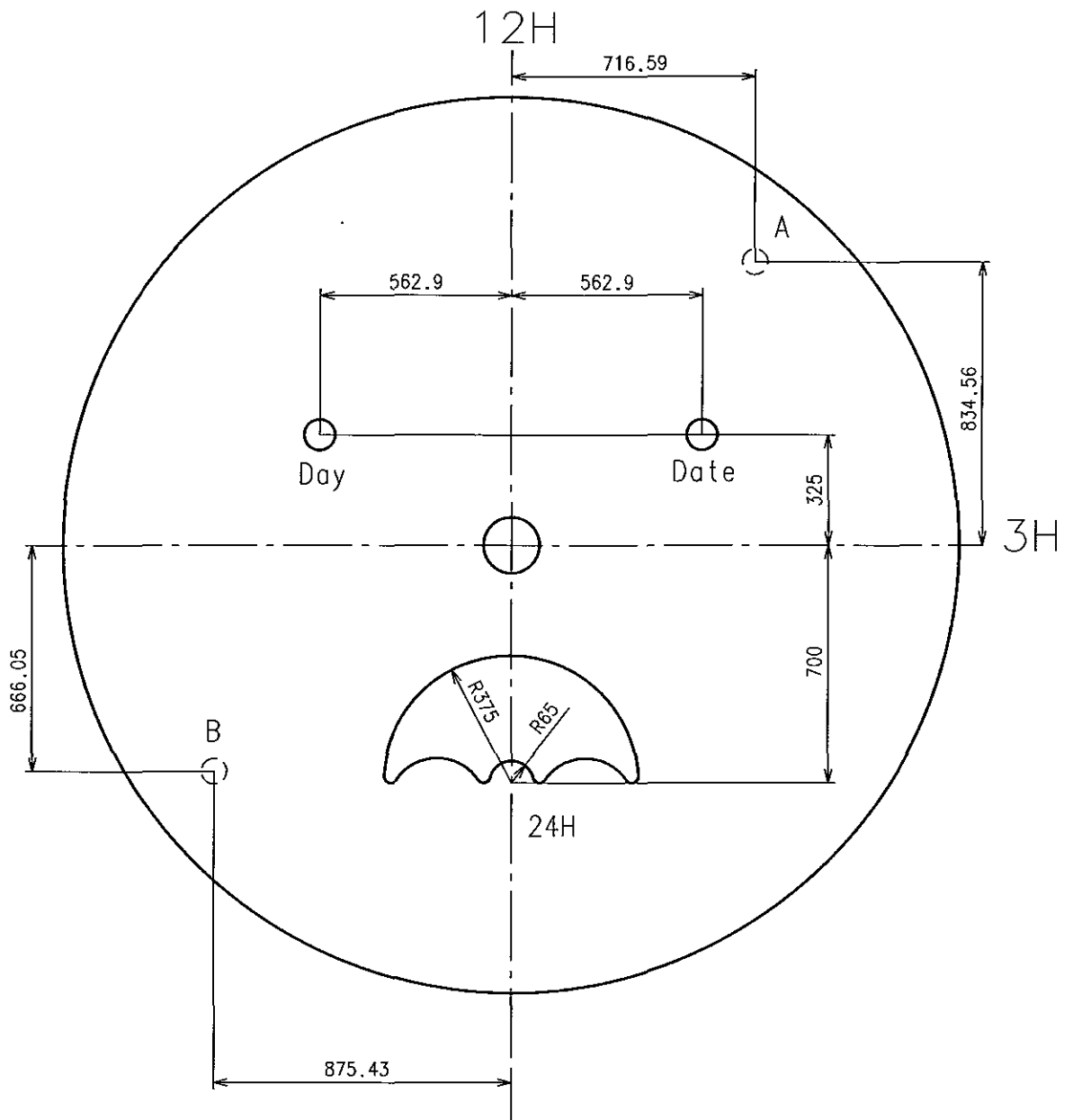

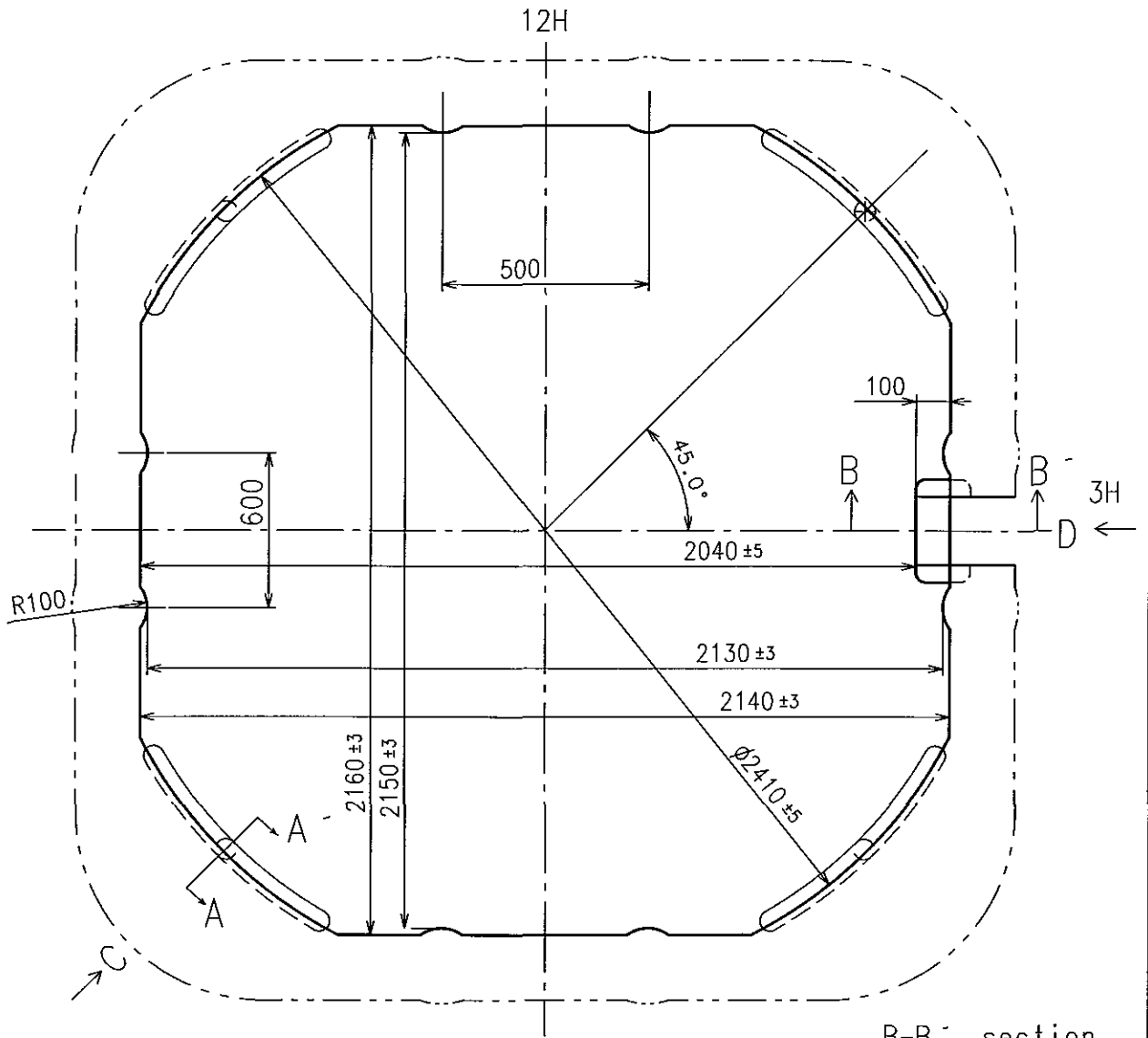

B-B section

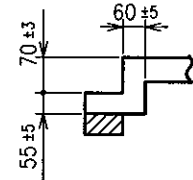

A-A section

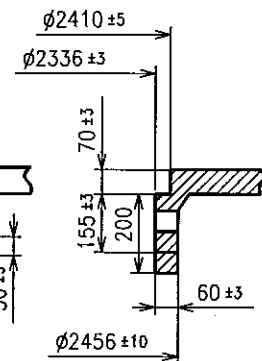

D view

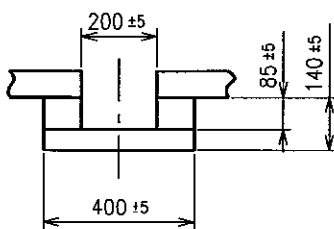

C view

